

### “Breakthrough Motor Design Offers Huge Energy Savings For The Refrigeration Market”

**New Design!**  
For Evaporator & Condenser Application

Stock No. 9207F2, 9208F2



**iMotor®**



**9 & 16 WATT**  
Replaces 6-16 watt PSC & low efficiency shaded pole motors

**Direct Drop-in Replacement for supermarket case evaporator fans and condenser units.**

**Features:**

- ✓ Advanced ECM Design
- ✓ Rain Shield
- ✓ Cast Iron
- ✓ 15” Leads
- ✓ Lyall Plug
- ✓ UL Approved E128044
- ✓ Up to 65% Efficiency
- ✓ Wide temperature range oil for use in evaporators and condensers
- ✓ Tapped & Drilled Mounting Holes
  - Evaporator Mount Standard 3-hole
  - Hussmann 4-hole style
  - Condenser Mount-Double Boss



(Energy Savings ECM Design)

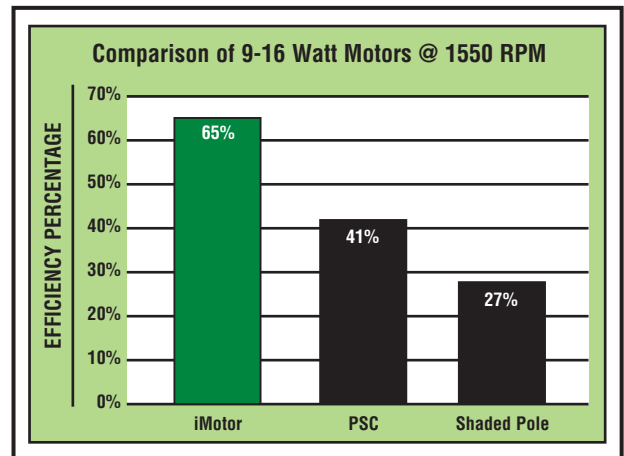

Stock No.	Watts	Volts	Amps	ROT OSE	RPM
<b>New!</b> 9207F2	6, 9, 12	115	.20 - .30	CW	1550
<b>New!</b> 9208F2	14, 15, 16	115	.47 - .58	CW	1550

Divisional Headquarters  
A. O. Smith Electrical Products Company  
531 North Fourth Street  
Tipp City, OH 45371  
A DIVISION OF A. O. SMITH CORPORATION

**NOW AVAILABLE!  
FAX OR PHONE YOUR ORDER TODAY!**

Distribution Services  
1325 Heil Quaker Blvd.  
LaVergne, TN 37086  
(800) 672-6495  
Fax: (800) 468-2062  
www.aosmithmotors.com

# Evaporator Fan Replacement For Hussman, Hill & Kysor

Stock No. 9207F2, 9208F2

Cast iron bearing and housing for long life and reliability

High capacity oil reservoir continuously supplies cooled, filtered oil thru the bearing.

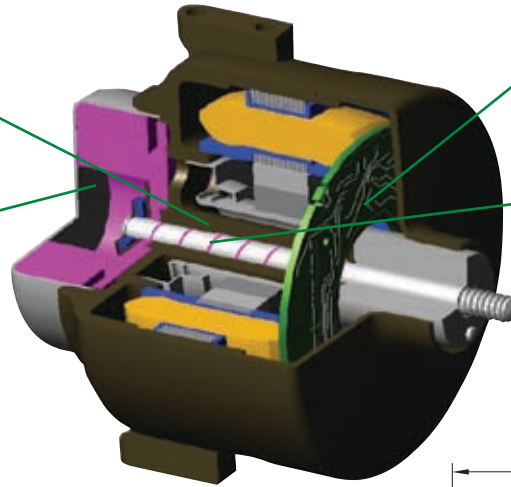

Electronic control board

Spiral grooved shaft is the heart of the positive pumping system, assuring thick film lubrication for extended bearing life.

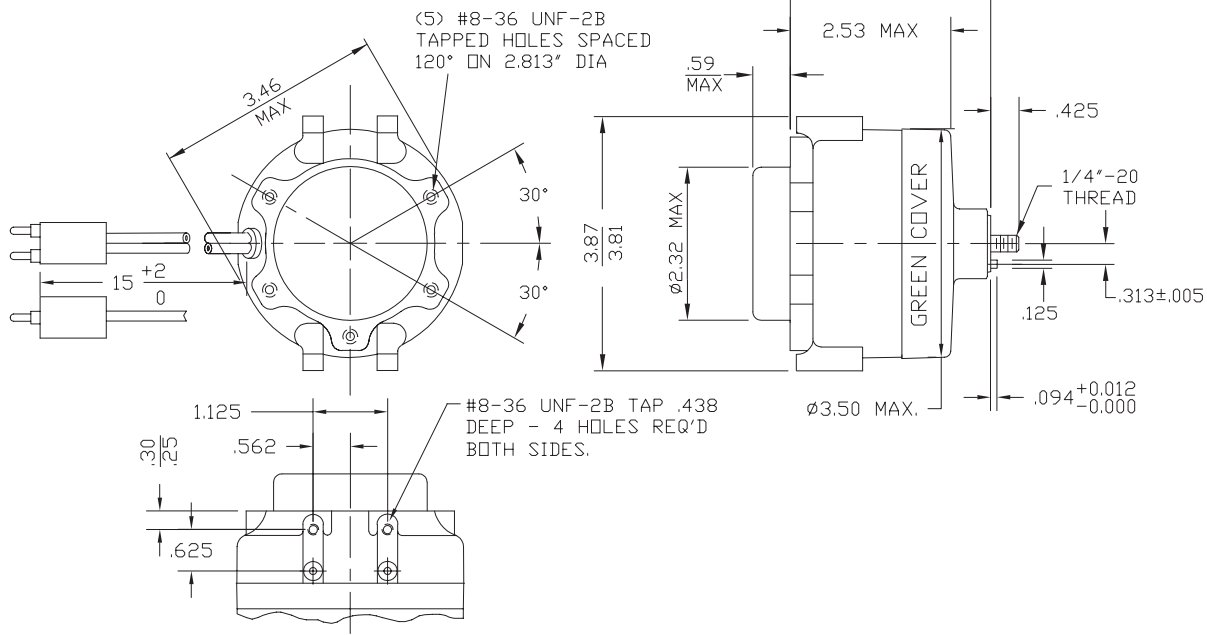

*"The iMotor refrigeration motor uses less wattage to achieve the same airflow as a shaded pole motor, so it produces less heat. Fewer BTU's in the system means less work and wear for the compressor for even greater savings."*

## Annual KWH Savings For a Typical 9W or 16W Motor

Motor Output	Shaded Pole Watts In	iMotor Watts In	Annual KWH Saved
9 Watts	51.8	17.7	298.7
16 Watts	64.0	27.0	324.0

