

A.O.SMITH ELECTRICAL PRODUCTS COMPANY

A DIVISION OF A.O.SMITH CORPORATION



NEW PRODUCT ANNOUNCEMENT

NEW!

OEM REPLACEMENT FOR KRACK



**Includes
Quick Connect
OEM Plug**

Stock No. 9627
Krack Part No. 11528 (115V)

Replacement for:
AOS JA2P216
Emerson 9654 (115/230V)
Fasco 8254111030
Fasco D1189 (115/230V)
Krack 11528

Stock No. 9628
Krack Part No. 11529 (200-230V)

Replacement for:
AOS JA2P217
AOS JA2S149
Emerson 9654 (115/230V)
Fasco 8254160210
Fasco D1189 (115/230V)
Krack 11529

Features for Both:

- Direct OEM Replacements: No Modifications Required
- Shaded Pole
- Sleeve Bearing
- Thermally Protected
- 40° C Ambient
- Single Phase
- 50/60 Hertz
- Insulation Class B
- Enclosed
- Lug Mount
- Lead and Plug Assembly
- UL and CSA Approved
- See Reverse Side for Outline Drawing

Stock No.	HP	Volts	Amps	RPM	Speeds	Frame Size	Rotation	Wt.
9627	1/25	115	1.5/1.3	1250/1550	1	3.3"	CWSE	4.5
9628	1/20	200-230	0.90	1550	1	3.3"	CWSE	5.5

Distribution Services
531 North Fourth Street
Tipp City, OH 45371

NOW AVAILABLE!
FAX OR PHONE YOUR ORDER TODAY!

(800) 672-6495
Fax: (800) 468-2062
www.aosmithmotors.com

**OEM REPLACEMENT FOR KRACK
STOCK NO. 9627**

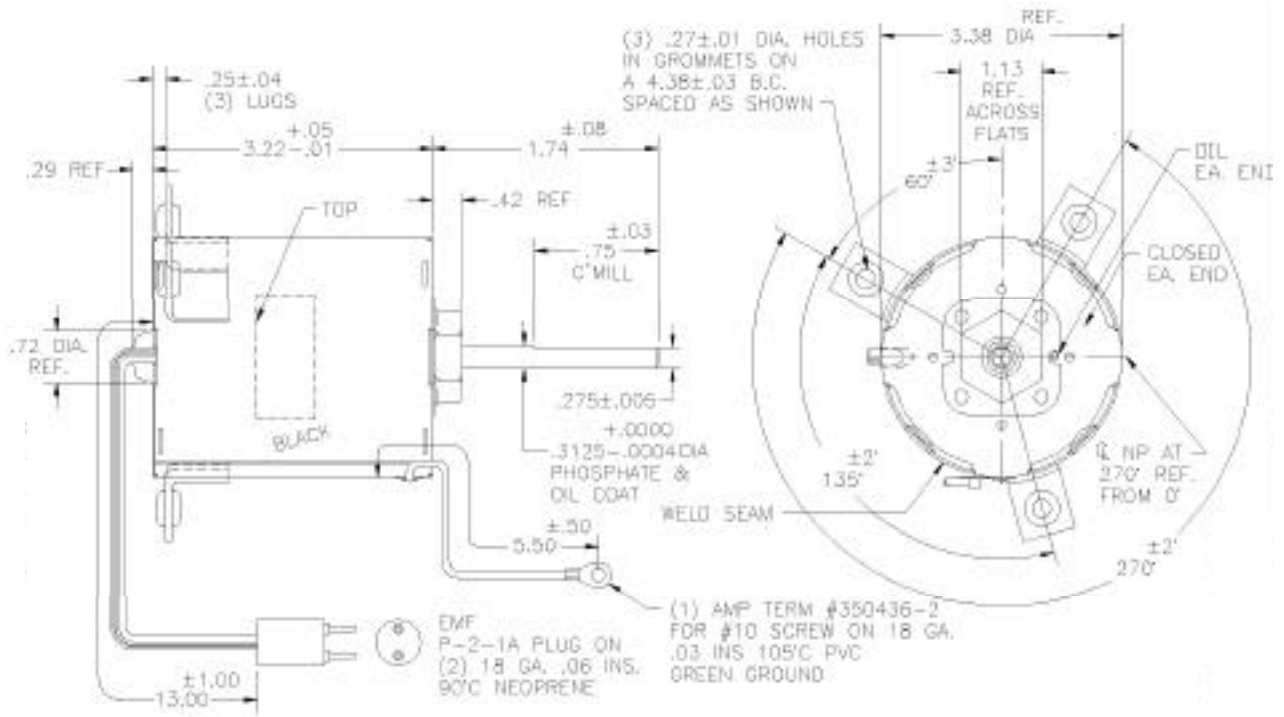

**OEM REPLACEMENT FOR KRACK
STOCK NO. 9628**

