

A.O.SMITH ELECTRICAL PRODUCTS COMPANY

A DIVISION OF A.O.SMITH CORPORATION



NEW PRODUCT ANNOUNCEMENT

NEW!

OEM REPLACEMENT FOR KRACK



**Includes
Quick Connect
OEM Plug**

Stock No. 9633
Krack Part No. E206447 (115V)

Replacement for:
AOS JE2F029
Krack E206447

Stock No. 9634
Krack Part No. E206448 (208-230V)

Replacement for:
AOS JE2F030
Krack E206448

Features for Both:

- Direct OEM Replacements: No Modifications Required
- Permanent Split Capacitor
- Capacitor Included
- Sleeve Bearing
- Thermally Protected
- 40° C Ambient
- Single Phase
- 50/60 Hertz
- Insulation Class B
- Open
- Stud Mount
- Lead and Plug Assembly
- UL and CSA Approved
- See Reverse Side for Outline Drawing

Stock No.	HP	Volts	Amps	RPM	Speeds	Frame Size	Rotation	Wt.
9633	1/15	115	0.8/0.7	1350/1640	1	3.3"	CWSE	4.25
9634	1/15	208-230	0.4/0.3	1350/1640	1	3.3"	CWSE	4.25

Distribution Services
531 North Fourth Street
Tipp City, OH 45371

NOW AVAILABLE!
FAX OR PHONE YOUR ORDER TODAY!

(800) 672-6495
Fax: (800) 468-2062
www.aosmithmotors.com

**OEM REPLACEMENT FOR KRACK
STOCK NO. 9633**

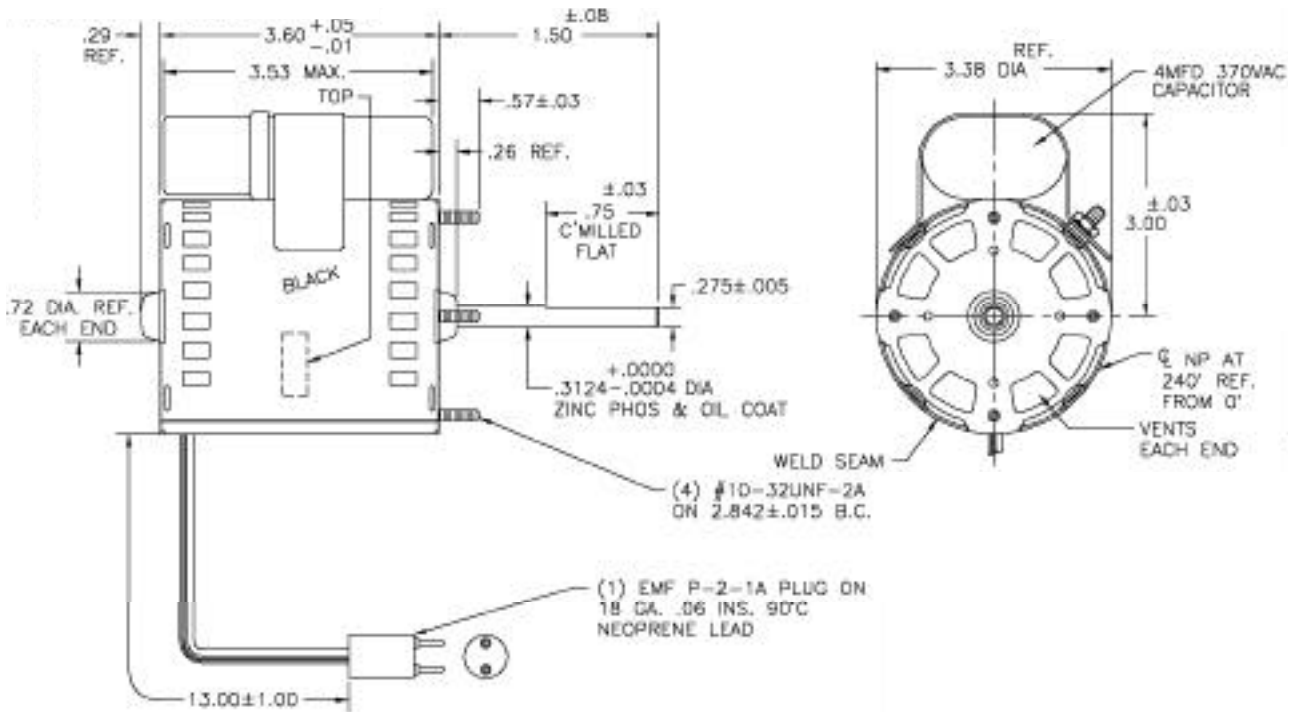

**OEM REPLACEMENT FOR KRACK
STOCK NO. 9634**

