

## Totally Enclosed Fan Cooled

### Shaded Pole & PSC— 60 Hz

OEM replacement for: Coleman, Tjerlund, Trane, Frigidaire, McQuay and similar applications.

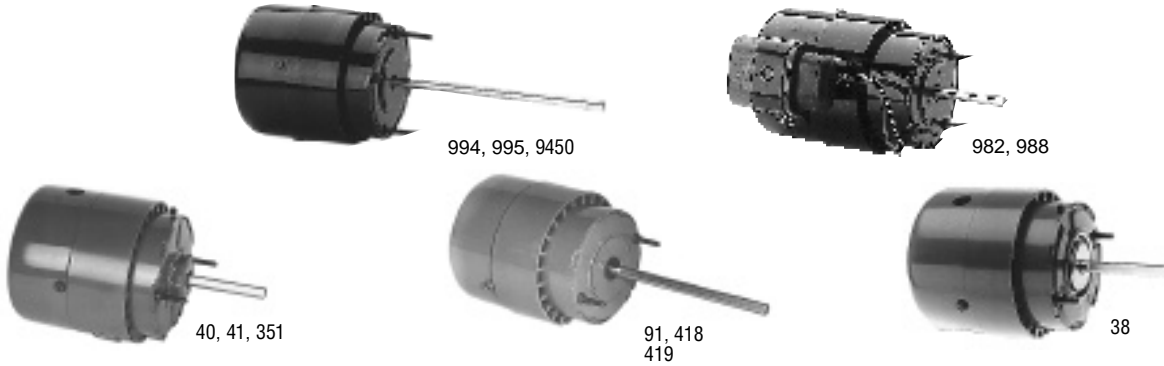

Stock No.	Rotation	Hp	Volts	RPM	Amps	Speeds	Capacitor	"A"	Shaft Diameter & Length	Iron Stack	Connection Diagram No.*	Notes
38	CWSE	1/25	115	1550	1.2	1	S.P.	4-1/8	5/16 x 2-1/2	1-3/8		
40	CWSE	1/20	115	1550	1.5	1	S.P.	4-1/8	5/16 x 2-1/2	1-5/8		
41	CCWSE	1/20	115	1550	1.5	1	S.P.	4-1/8	5/16 x 2-1/2	1-5/8		
351	CWSE	1/20	115/230	1550	1.5/.74	1	S.P.	4-1/4	5/16 x 4-1/2	1-5/8	11u	4
419	CCWSE	1/20	115/230	1550	1.5/.74	1	S.P.	4-1/4	5/16 x 2-1/4	1-5/8	11u	4
91	CWSE	1/15	115/230	3000	2.0/1.0	1	S.P.	4-1/2	5/16 x 5	1-5/8	11u	1,4
418	CCWSE	1/15	115/230	3000	2.0/1.0	1	S.P.	4-1/2	5/16 x 5	1-5/8	11u	4
9450	CCWSE	1/15	115/230	3000	2.0/1.0	1	S.P.	4-1/2	5/16 x 6-1/2	1-5/8	11u	2,4
994	CCWSE	1/20	115/230	3000	1.9/.90	1	S.P.	4-3/8	5/16 x 6-1/2	1-5/8		4
995	CWSE	1/20	115/230	3000	1.9/.90	1	S.P.	4-3/8	5/16 x 6-1/2	1-5/8		2,4
982	REV	1/8	115	3000	2.0	1	FURNISHED	5-1/4	5/16 x 2-1/4	1-1/2		4
988	REV	1/20	115	3200	0.64	1	FURNISHED	4-1/2	5/16 x 2-1/4	3/4		4

## GE 11 Frame Replacements

Stock No. 671 Replaces 1231,1331,1431,1432  
 Stock No. 672 Replaces 1342, 1441,1442

Stock No. 9439 Replaces 1541S  
 Stock No. 9440 Replaces 1332  
 Stock No. 9524 Replaces 1232

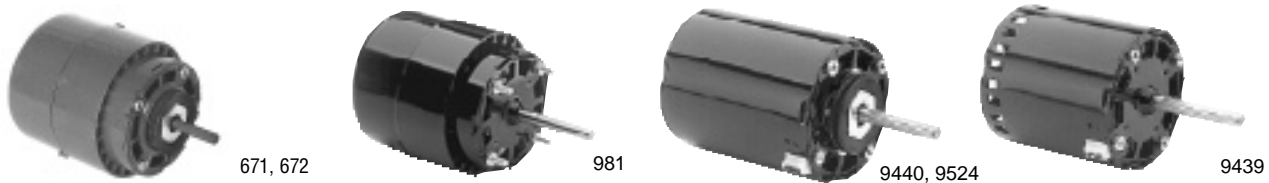

Stock No.	Rotation Opposite Shaft End	Hp	Volts	RPM	Amps	Speeds	"A"	Shaft Diameter & Length	Iron Stack	Connection Diagram No.*	Notes
671	CW	1/15	115/208-230	1550	2.1/1.0	1	4-7/8	5/16 x 2	1-5/8	11u	
672	CCW	1/15	115/208-230	1550	2.1/1.0	1	4-7/8	5/16 x 2	1-5/8	11u	
981	CCW	1/15	460	1550	.6	1	4-1/4	5/16 x 2-1/2	1-5/8		
9439	CW	1/15	230	1550	1.0/1.2	1	3-5/8	5/16 x 2-3/8	2-1/8		
9440	CW	1/15	208-230	1550	1.2	1	4-1/4	5/16 x 2	2-1/8		
9524	CW	1/15	230	1550	1.2	1	4-3/8	5/16 x 1-1/2	2-1/8		

- Notes:**  
 1. Stock No. 91 has a stainless steel shaft and 20" leads for use on ice machines  
 2. Motor has four studs  
 3. Special OEM Replacement Motor (See Pages 97-122)  
 4. Ball Bearings  
 \* See Pages 160-163 for Diagram