



USER'S MANUAL

MODELS

170-103-0002
170-103-0010
170-113-0002
170-113-0010
170-113-0102
170-113-0110
170-143-0002
170-143-0010

**SCR, Dual Voltage,
Adjustable Speed Drives
for PM DC Brush Motors**

Copyright © 2006 by
Bison

All rights reserved. No part of this manual may be reproduced or transmitted in any form without written permission from Bison. The information and technical data in this manual are subject to change without notice. Bison and its Divisions make no warranty of any kind with respect to this material, including, but not limited to, the implied warranties of its merchantability and fitness for a given purpose. Bison and its Divisions assume no responsibility for any errors that may appear in this manual and make no commitment to update or to keep current the information in this manual.

Printed in the United States of America.

Safety Warnings

- This symbol  denotes an important safety tip or warning. **Please read these instructions carefully** before performing any of the procedures contained in this manual.
- **DO NOT INSTALL, REMOVE, OR REWIRE THIS EQUIPMENT WITH POWER APPLIED.** Have a qualified electrical technician install, adjust and service this equipment. Follow the National Electrical Code and all other applicable electrical and safety codes, including the provisions of the Occupational Safety and Health Act (OSHA), when installing equipment.
- Reduce the chance of an electrical fire, shock, or explosion by proper grounding, over-current protection, thermal protection, and enclosure. Follow sound maintenance procedures.



It is possible for a drive to run at full speed as a result of a component failure. Bison strongly recommends the installation of a master switch in the main power input to stop the drive in an emergency.

Circuit potentials are at 115 VAC or 230 VAC above earth ground. Avoid direct contact with the printed circuit board or with circuit elements to prevent the risk of serious injury or fatality. Use a non-metallic screwdriver for adjusting the calibration trim pots. Use approved personal protective equipment and insulated tools if working on this drive with power applied.

Contents

Safety Warnings	i
Specifications	1
Dimensions	3
Installation	7
Chassis drives	7
Mounting	7
Wiring	8
Shielding guidelines	9
Speed adjust potentiometer	10
Line fusing	11
Heat sinking	12
Connections	12
Power, fuse and motor connections	13
Motor	13
Power input	13
Line fuse	13
Master power switch	14
Alternate speed adjust potentiometer connections	14
Voltage follower	16
Cased drives	17
Mounting (NEMA 1 enclosures)	17
Mounting (NEMA 4X enclosures)	18
Heat sinking	19
Line fusing	19
All drives	20
Operation	22
Switch settings	23
Before applying power	24
Speed Mode	25
Torque Mode	25
Speed Mode Startup	27
170-103-0010 and 170-103-0002	27
170-113-0010, 170-113-0002, 170-143-0010 and 170-143-0002	27
170-113-0110 and 170-113-0102	28
Starting and Stopping Methods	29

Line starting and line stopping	29
Inhibit terminals	30
Decelerating to minimum speed	32
Dynamic braking	33
Dynamic brake resistor value	33
Calibration	35
MIN SPD	37
MAX SPD	37
TORQUE	38
IR COMP	39
ACCEL	40
DECEL	41
Torque Mode Calibration	42
Application Notes	44
Multiple fixed speeds	44
Adjustable speeds using potentiometers in series	45
Independent adjustable speeds	46
RUN / JOG switch	47
Leader-follower application	49
Single speed potentiometer control of multiple drives	50
Reversing	51
Troubleshooting	52
Before troubleshooting	52
Diagnostic LEDs	53
Power (PWR):	53
Current Limit (CURR LIMIT or CL):	53
Functional Diagrams	57
Certificate of Compliance	60
Line Filters	61
Unconditional Warranty	inside back cover

Illustrations

Figure 1.	170-103-0010 and 170-103-0002 Dimensions	.3
Figure 2.	170-113-0010, 170-113-0002, 170-113-0110, and 170-113-0102 Dimensions	.4
Figure 3.	170-143-0010 and 170-143-0002 Dimensions	.5
Figure 4.	Heat Sink Dimensions	.6
Figure 5.	Speed Adjust Potentiometer	.10
Figure 6.	Chassis Drive Connections	.15
Figure 7.	Voltage Follower Connections	.16
Figure 8.	Cased Drive Connections	.21
Figure 9.	Voltage Switches	.23
Figure 10.	J503 SPEED/TORQUE Jumper Settings	.26
Figure 11.	J503 SPEED/TORQUE Jumper Location	.26
Figure 12.	INHIBIT Terminals	.30
Figure 13.	Inhibit Personality Configuration	.31
Figure 14.	Run/Decelerate to Minimum Speed Switch	.32
Figure 15.	Dynamic Brake Connection	.34
Figure 16.	Calibration Trimpot Layout	.36
Figure 17.	Recommended Torque and IR COMP Settings	.43
Figure 18.	Multiple Fixed Speeds	.44
Figure 19.	Adjustable Fixed Speeds Using Potentiometers in Series	.45
Figure 20.	Independent Adjustable Speeds	.46
Figure 21.	RUN / JOG Switch Connection to Inhibit Plug	.47
Figure 22.	RUN / JOG Switch Connection to Speed Adjust Potentiometer	.48
Figure 23.	Leader-Follower Application	.49
Figure 24.	Single Speed Potentiometer Control of Multiple Drives	.50
Figure 25.	Reversing Circuit Connection	.51
Figure 26.	Diagnostic LED Locations	.53
Figure 27.	Block Diagram	.57
Figure 28.	170-113-0010, 170-113-0002, 170-143-0010 and 170-143-0002 Terminal Block Connections	.58
Figure 29.	170-113-0110 and 170-113-0102 Terminal Block Connections	.59

Tables

Table 1.	Recommended Line Fuse Sizes	.11
Table 2.	Corcom® Filters	.61

Specifications

Model	Max. Armature Current (Amps DC)	HP Range with 115 VAC Applied	HP Range with 230 VAC Applied	Style
170-103-0002	1.5	1/20–1/8	1/10–1/4	Chassis
170-113-0002				NEMA 1
170-113-0102				NEMA 1
170-143-0002				NEMA 12/4/4X
170-103-0010 †	5.0	1/8–1/2	1/4–1	Chassis
170-113-0010 ‡				NEMA 1
170-113-0110 ‡				NEMA 1
170-143-0010	10.0	1/8–1	1/4–2	NEMA 12/4/4X

† Double maximum armature current and horsepower when drive is mounted on heat sink part number 170-990-0100.

‡ Double maximum armature current and horsepower when drive is mounted on heat sink part number 170-990-0300.

AC Line Voltage	115 VAC or 230 VAC $\pm 10\%$, 50/60 Hz, single phase
Armature Voltage (115 VAC Input)	0–90 VDC
Armature Voltage (230 VAC Input)	0–180 VDC
Form Factor	1.37 at base speed
Accel. Time Range	
(for 0–90 VDC Armature Voltage)	0.5–17 seconds
(for 0–180 VDC Armature Voltage)	0.5–17 seconds
Decel. Time Range	
(for 0–90 VDC Armature Voltage)	coast to a stop–25 seconds
(for 0–180 VDC Armature Voltage)	coast to a stop–25 seconds
Analog Input Voltage Range (input must be isolated; S1 to S2)	0–2.5 VDC
Input Impedance (S1 to S2)	100K ohms
Speed adjust potentiometer rating	10k ohm, 5W (5k ohms acceptable)
Load Regulation	1% base speed or better

Vibration	0.5G max (0–50 Hz) 0.1G max (>50 Hz)
Safety Certification	UL Recognized Component, file # E132235 CSA Certified Component, file # LR41380 CE Certificate of Compliance
Ambient Temp. Range (chassis drive)	10°C–55°C
Ambient Temp. Range (cased drive)	10°C–40°C

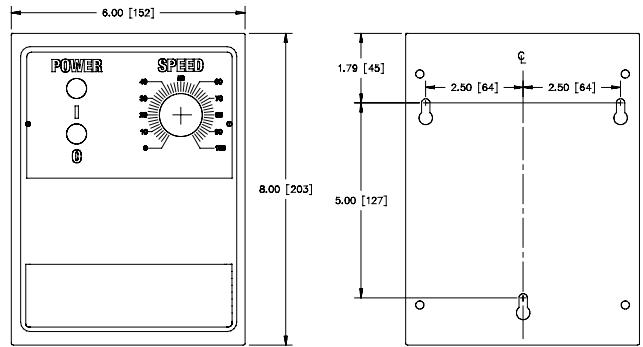

THREE KEYHOLES FOR #10
SCREW ON BACK SIDE
FOR MOUNTING

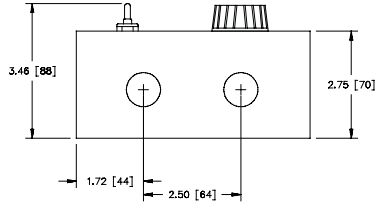

TWO 0.88 [22] CONDUIT HOLES
ON BOTTOM SIDE

ALL DIMENSIONS IN INCHES [MILLIMETERS]

Figure 2. 170-113-0010, 170-113-0002, 170-113-0110, and 170-113-0102 Dimensions

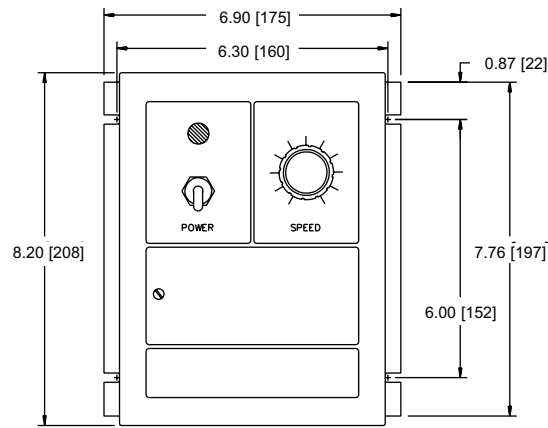

FOUR MOUNTING SLOTS 0.19 INCHES [5 MILLIMETERS] WIDE

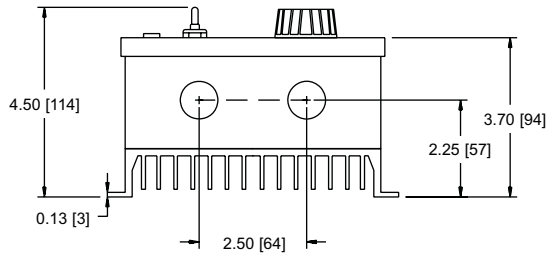

TWO 0.88 [22] CONDUIT KNOCKOUTS ON BOTTOM SIDE
ALL DIMENSIONS IN INCHES [MILLIMETERS]

Figure 3. 170-143-0010 and 170-143-0002 Dimensions

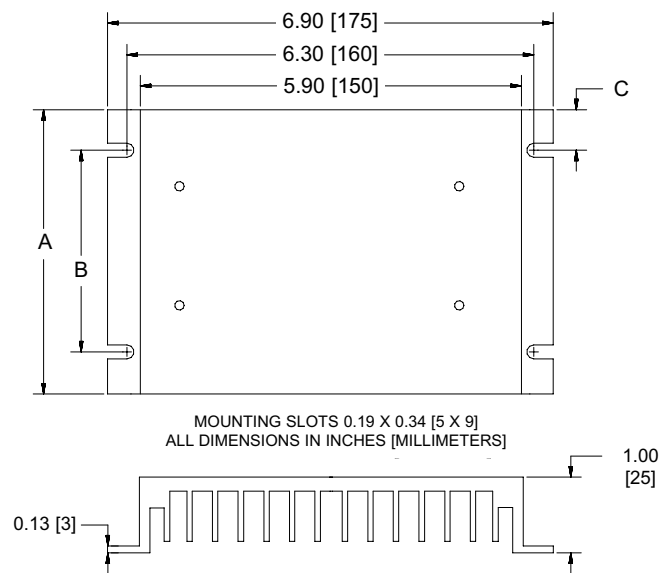

PART NO.	DIM "A"	DIM "B"	DIM "C"
170-990-0100	4.40 [112]	3.00 [76]	0.7 [18]
170-990-0300	7.78 [198]	6.00 [152]	0.89 [23]

Heat sinks sold separately.

Figure 4. Heat Sink Dimensions

Installation

Chassis drives

Mounting



Warning

Do not install, rewire, or remove this control with power applied. Doing so may cause fire or serious injury. Make sure you have read and understood the Safety Warnings before attempting installation.

The chassis must be earth grounded. Use a star washer beneath the head of at least one of the mounting screws to penetrate the anodized chassis surface and to reach bare metal.

- Drive components are sensitive to electrostatic fields. Avoid contact with the circuit board directly. Hold the drive by the chassis only.
- Mount the drive with its board in either a horizontal or vertical plane. Six 0.19 inch (5 mm) wide slots in the chassis accept #8 pan head screws. Fasten either the large base or the narrow flange of the chassis to the subplate.

Wiring



Warning



Do not install, remove, or rewire this equipment with power applied. Failure to heed this warning may result in fire, explosion, or serious injury.

Circuit potentials are at 115 or 230 VAC above ground. To prevent the risk of injury or fatality, avoid direct contact with the printed circuit board or with circuit elements.

Do not disconnect any of the motor leads from the drive unless power is removed or the drive is disabled. Opening any one motor lead may destroy the drive.

- Use 18-24 AWG wire for speed adjust potentiometer wiring.
Use 14–16 AWG wire for AC line (L1, L2) and motor (A1 and A2) wiring.

Shielding guidelines



Warning

Under no circumstances should power and logic leads be bundled together. Induced voltage can cause unpredictable behavior in any electronic device, including motor controls.

As a general rule, Bison recommends shielding of all conductors.

If it is not practical to shield power conductors, Bison recommends shielding all logic-level leads. If shielding is not practical, the user should twist all logic leads with themselves to minimize induced noise.

It may be necessary to earth ground the shielded cable. If noise is produced by devices other than the drive, ground the shield at the drive end. If noise is generated by a device on the drive, ground the shield at the end away from the drive. Do not ground both ends of the shield.

If the drive continues to pick up noise after grounding the shield, it may be necessary to add AC line filtering devices, or to mount the drive in a less noisy environment.

Speed adjust potentiometer



Warning

Be sure that the potentiometer tabs do not make contact with the potentiometer enclosure. Grounding the input will cause damage to the drive.

On chassis drives, install the circular insulating disk between the panel and the 10K ohm speed adjust potentiometer. Mount the speed adjust potentiometer through a 0.38 inch (10 mm) hole with the hardware provided (Figure 5). Twist the speed adjust potentiometer wire to avoid picking up unwanted electrical noise. If potentiometer leads are longer than 18 inch (457 mm), use shielded cable.

All cased controls come with the speed adjust potentiometer installed.

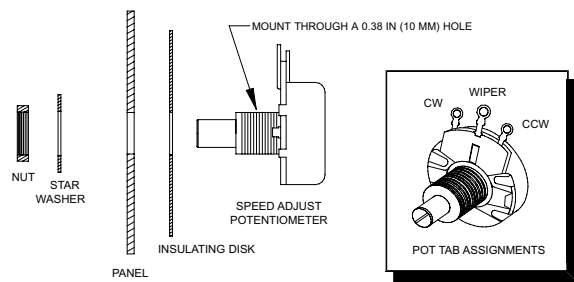

Figure 5. Speed Adjust Potentiometer

Line fusing

Bison drives require an external fuse for protection. Use fast acting fuses rated for 250 VAC or higher, and approximately 150% of the maximum armature current. Fuse only the hot leg of the AC line that connects to L1 and leave L2 unfused when the AC line voltage is 115 VAC. Fuse both L1 and L2 when the AC line voltage is 230 VAC. Fuse blocks are included on cased drives only. Table 1 lists the recommended line fuse sizes.

Table 1. Recommended Line Fuse Sizes

90 VDC Motor Horsepower	180 VDC Horsepower	Max. DC Armature Current (amps)	AC Line Fuse Size (amps)
1/20	1/10	0.5	1
1/15	1/8	0.8	1.5
1/8	1/4	1.5	3
1/6	1/3	1.7	3
1/4	1/2	2.6	5
1/3	3/4	3.5	8
1/2	1	5.0	10
3/4	1 1/2	7.6	15
1	2	10	15

Heat sinking

Model 170-103-0010 requires an additional heat sink, Bison part number 170-990-0100, when the continuous armature current is above 5 ADC. All other chassis drives have sufficient heat sinking in their basic configurations. Use a thermally conductive heat sink compound (such as Dow Corning® 340 Heat Sink Compound) between the drive chassis and heat sink surface for optimum heat transfer.

Connections



Warning

Do not connect this equipment with power applied.

Failure to heed this directive may result in fire or serious injury.

For chassis drives, Bison strongly recommends the installation of a master power switch in the voltage input line as shown in Figure 6 (page 15). The switch contacts should be rated at a minimum of 200% of motor nameplate current and 250 volts.

Power, fuse and motor connections

Connect the power input leads, an external line fuse and a DC motor to the drive's printed circuit board (PCB) as shown in Figure 6, page 15.

Motor

Connect a motor to PCB terminals A1 and A2. **Ensure that the motor voltage rating is consistent with the drive's output voltage.**

Power input

Connect the AC line power leads to terminals L1 and L2, or to a double-pole, single-throw master power switch as shown in Figure 6, page 15 (recommended).

Line fuse

Wire an external line fuse between the stop switch (if installed) and the L1 terminal on the PCB. An additional line fuse should be installed on L2 if the input voltage is 230VAC. The line fuse(s) should be rated at 250 volts and 150 - 200% of maximum motor nameplate current. Refer to the Table 1 on page 11 for fuse ratings.

**Master power switch**

If you use a chassis (uncased) drive, Bison strongly recommends the installation of a master power switch in the voltage input line, as shown in Figure 6. The switch contacts should be rated at a minimum of 200% of motor nameplate current and 250 volts.

Alternate speed adjust potentiometer connections

Refer to Application Notes section (page 44) for additional speed adjust potentiometer connections.

Voltage follower

Instead of using an external speed or torque adjust potentiometer, the drive may be wired to follow an analog input voltage signal that is **isolated** (Figure 7). The analog input voltage range is 0 - 2.5 VDC.

Connect the signal input (+) to S2. Connect the signal common (-) to S1. Make no connection to S3. A potentiometer can be used to scale the analog input voltage. An interface device such as Bison model 170-993-0200, may be used to scale and isolate an analog input voltage.

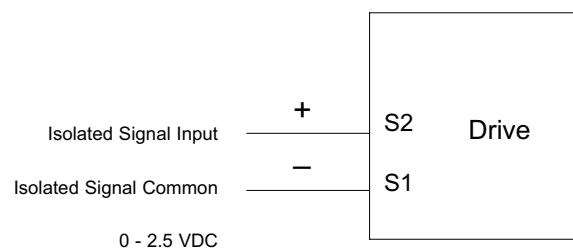

Figure 7. Voltage Follower Connections

Cased drives

Mounting (NEMA 1 enclosures)

NEMA 1 cased drives come with 0.88 inch (22 mm) conduit holes at the bottom of the case. The units may be vertically wall mounted or horizontally bench mounted using the three keyholes on the back of the case (see Figure 2, page 4).

1. For access to the keyholes and the terminal strip, remove the two screws from the front of the case by turning them counterclockwise. Grasp the front cover and lift it straight out.
2. Install the mounting screws in the three keyholes.
3. Install conduit hardware through the conduit holes at the bottom of the case. Connect external wiring to the terminal block. Refer to Figure 8 on page 21.
4. Reinstall the front cover. Avoid pinching any wires between the front cover and the case.
5. Replace the two screws to the front cover. Turn the screws clockwise to tighten.
6. Set the POWER switch to the OFF position before applying the AC line voltage.

Mounting (NEMA 4X enclosures)

NEMA 4X cased drives come with two 0.88 inch (22 mm) conduit knockout holes at the bottom of the case. The units may be vertically wall mounted using the four 0.19 inch (5 mm) slotted holes on the attached heat sink (see Figure 3, page 5). For motor loads less than 5 ADC, the drive may be bench mounted horizontally, or operated without mounting.

1. Install the mounting screws.
2. For access to the terminal strip, turn the slotted screw on the front cover counterclockwise until it is free from the case. The right side of the cover is hinged to the case. Pull the slotted screw to open the case.
3. Carefully remove the conduit knockouts by tapping them into the case and twisting them off with pliers.
4. Install conduit hardware through the 0.88 inch (22 mm) conduit holes. Connect external wiring to the terminal block.
5. Grasp the slotted screw and tilt the front cover back into place. Avoid pinching any wires between the front cover and the case.
6. Turn the slotted screw clockwise until tight to secure the front cover.
7. Set the POWER switch to the OFF position before applying the AC line voltage.

Heat sinking

Models 170-113-0010 and 170-113-0110 require additional heat sinking when the continuous armature current is above 5 ADC. Use Bison part number 170-990-0300. All other cased drives have sufficient heat sinking in their basic configurations. Use a thermally conductive heat sink compound (such as Dow Corning® 340 Heat Sink Compound) between the back of the drive case and heat sink surface for optimum heat transfer.

Line fusing

15-amp line fuses are preinstalled on models 170-113-0010, 170-113-0110 and 170-143-0010 and 3-amp line fuses are preinstalled on models 170-113-0002, 170-113-0102, and 170-143-0002.

If the horsepower rating of the motor being used is less than the maximum horsepower rating of the drive, the line fuse may have to be replaced with a lower rated one. Refer to the “Recommended Line Fuse Sizes”, Table 1 on page 11 to install a lower rated fuse.

All drives

- Protect the drive from dirt, moisture, and accidental contact. Provide sufficient room for access to the terminal block and calibration trimpots.
- Mount the drive away from other heat sources. Operate the drive within the specified ambient operating temperature range.
- Prevent loose connections by avoiding excessive vibration of the drive.

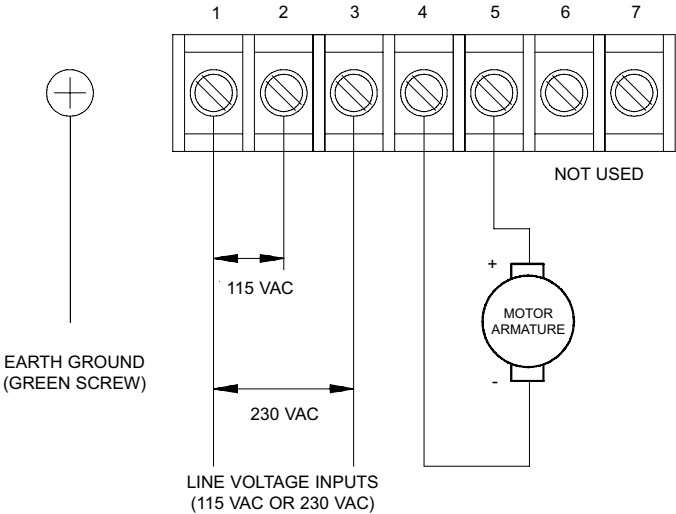

Figure 8. Cased Drive Connections

Operation



Warning

Dangerous voltages exist on the drive when it is powered. BE ALERT. High voltages can cause serious or fatal injury.

Change voltage switch settings only when the drive is disconnected from AC line voltage. Make sure both switches are set to their correct position. If the switches are improperly set to a lower voltage position, the motor will not run at full voltage and may cause damage to the transformer. If the switches are improperly set to a higher voltage position, the motor will overspeed, which may cause motor damage.

Switch settings

Set voltage switch SW501 and SW502 to either 115V or 230V to match the AC line voltage.

Set voltage switch SW503 to either 90V or 180V to match the maximum armature voltage. Refer to Figure 9 for switch locations.

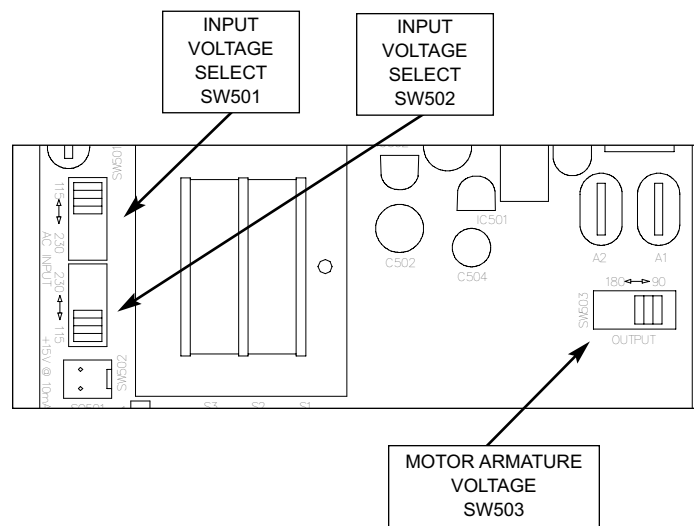

Figure 9. Voltage Switches

Before applying power



Warning

If the motor does not respond as desired to signal input, remove line power immediately. Refer to the Troubleshooting section on page 52 for assistance.

- Ensure that all selector switches are set to their proper positions.
- Verify that no conductive material is present on the printed circuit board.
- If using a 90 VDC or 130 VDC motor with 230 VAC line voltage, derate the nameplate motor speed and torque by at least 30%. Contact the factory for details.

**Warning**

TORQUE and MAX SPD trimpots must be recalibrated everytime the drive is switched between SPEED and TORQUE mode.

Speed Mode

In Speed Mode, the external potentiometer adjusts the speed (voltage) of the motor. The on-board Torque trimpot sets the maximum torque available. The drive comes factory calibrated for speed mode.

To run the drive in Speed Mode, jumper pins 2 & 3 and pins 4 & 5 on J503. See Figure 10 and Figure 11 on page 26.

Torque Mode

In Torque Mode, the external potentiometer adjusts the torque (current) of the motor. The on-board MAX SPD trimpot sets the maximum torque limit. The on-board TORQUE trimpot sets the maximum speed to the motor.

To run the drive in Torque Mode, jumper pins 1 & 2 and pins 3 & 4 on J503. See Figure 10 and 11 on page 26.

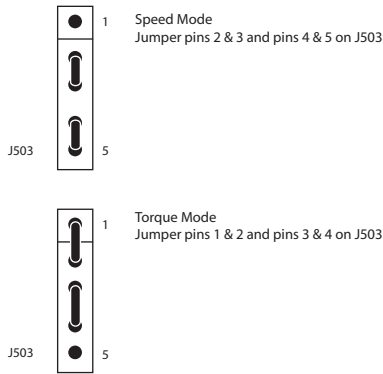

Figure 10. J503 SPEED/TORQUE Jumper Settings

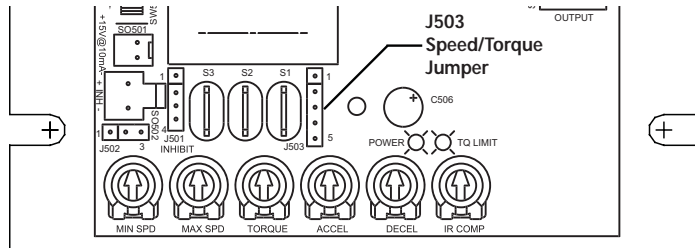

Figure 11. J503 SPEED/TORQUE Jumper Location

Speed Mode Startup

170-103-0010 and 170-103-0002

1. Turn the speed adjust potentiometer full counterclockwise (CCW).
2. Apply AC line voltage.
3. Slowly advance the speed adjust potentiometer clockwise (CW). The motor slowly accelerates as the potentiometer is turned CW. Continue until the desired speed is reached.
4. Remove AC line voltage from the drive to coast the motor to a stop.

170-113-0010, 170-113-0002, 170-143-0010 and 170-143-0002

1. Set the speed adjust potentiometer to "0" (full CCW).
2. Apply AC line voltage.
3. Set the POWER switch to the ON position.
4. Slowly advance the speed adjust potentiometer clockwise (CW). The motor slowly accelerates as the potentiometer is turned CW. Continue until the desired speed is reached.
5. Set the POWER switch to the OFF position to coast the motor to a stop.

170-113-0110 and 170-113-0102**Warning**

Do not change the FORWARD / REVERSE switch while the motor is running. The motor must come to a complete stop before reversing. Changing motor direction before allowing the motor to completely stop will cause excessively high current to flow in the armature circuit, and will damage the drive and/or motor.

1. Set the RUN / BRAKE switch to the BRAKE position.
2. Set the speed adjust potentiometer to "0" (full CCW).
3. Apply AC line voltage.
4. Set the POWER switch to the ON position.
5. Set the FORWARD / REVERSE switch to the desired direction of rotation.
6. Set the RUN/BRAKE switch to the RUN position.
7. Slowly advance the speed adjust potentiometer clockwise (CW). The motor slowly accelerates as the potentiometer is turned CW. Continue until the desired speed is reached.
8. To reverse direction:
 - a. Set the RUN / BRAKE switch to the BRAKE position.
 - b. Set the FORWARD / REVERSE switch to the desired direction of rotation.
 - c. Set the RUN / BRAKE switch to the RUN position.
9. To brake the motor, set the RUN / BRAKE switch to the BRAKE position. To coast the motor to a stop, set the POWER switch to the OFF position.

Starting and Stopping Methods



Warning

Bison strongly recommends the installation of an emergency stop switch. The switch contacts should be rated at a minimum of 125 volts and 200% of maximum motor current.

For frequent starts and stops, short the inhibit terminals, decelerate to a minimum speed, or apply a dynamic brake to the motor. Do not use any of these methods for emergency stopping. They may not stop a drive that is malfunctioning.

Removing AC line power (both L1 and L2) is the only acceptable method for emergency stopping.

Frequent starting and stopping can produce high torque. This may cause damage to motors, especially gearmotors that are not properly sized for the application.

Line starting and line stopping

Line starting and line stopping (applying and removing AC line voltage) is recommended for infrequent starting and stopping of a drive only. When AC line voltage is applied to the drive, the motor accelerates to the speed set by the speed adjust potentiometer. When AC line voltage is removed, the motor coasts to a stop.

Inhibit terminals

Open or short the INHIBIT terminals to coast the motor to minimum or zero speed (see Figure 12 for INHIBIT terminal location). Reopen the INHIBIT terminals to accelerate the motor to set speed. The drive will exhibit different responses to shorting these terminals, depending on the way they are shorted (see Figure 13, page 31). The INHIBIT function is the same for Speed or Torque Mode.

Bison offers an accessory plug harness for connecting to the INHIBIT terminals: part number 170-998-0100 [inhibit plug with 36 inch (91 cm) leads].

Twist inhibit wires and separate them from other power-carrying wires or sources of electrical noise. Use shielded cable if the inhibit wires are longer than 18 inches (46 cm). If shielded cable is used, ground only one end of the shield to earth ground. Do not ground both ends of the shield. See Shielding Guidelines, page 9.

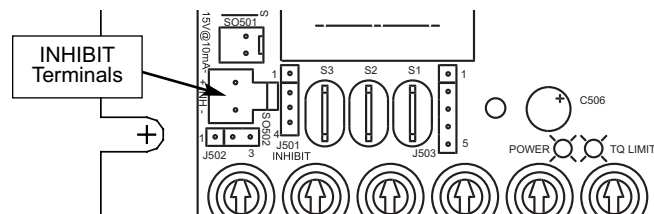

Figure 12. INHIBIT Terminals

CONFIGURATION	DRIVE RESPONSE
<p>INHIBIT TERMINALS S0502</p> <p>TERMINALS SHORTED</p>	<p>INHIBIT MIN MODE INHIBITS TO MINIMUM SPEED WHEN INHIBIT TERMINALS ARE SHORTED</p>
<p>INHIBIT TERMINALS S0502</p> <p>TERMINALS SHORTED</p>	<p>INHIBIT ZERO MODE INHIBITS TO ZERO SPEED WHEN INHIBIT TERMINALS ARE SHORTED</p>
<p>INHIBIT TERMINALS S0502</p> <p>TERMINALS SHORTED</p>	<p>INVERT INHIBIT MIN MODE INHIBITS TO MINIMUM SPEED WHEN INHIBIT TERMINALS ARE OPENED</p>
<p>INHIBIT TERMINALS S0502</p> <p>TERMINALS SHORTED</p>	<p>INVERT INHIBIT ZERO MODE INHIBITS TO ZERO SPEED WHEN INHIBIT TERMINALS ARE OPENED</p>

NOTE: The MAX and MIN SPD pots must be recalibrated everytime the **inhibit mode** (J501 or J502) jumpers are changed.

Figure 13. Inhibit Personality Configuration

Decelerating to minimum speed

The switch shown in Figure 14 may be used to decelerate a motor to a minimum speed. Closing the switch between S1 and S2 decelerates the motor from set speed to a minimum speed determined by the MIN SPD trimpot setting. If the MIN SPD trimpot is set full CCW, the motor decelerates to zero speed when the switch between S1 and S2 is closed. The DECEL trimpot setting determines the rate at which the drive decelerates. By opening the switch, the motor accelerates to set speed at a rate determined by the ACCEL trimpot setting.

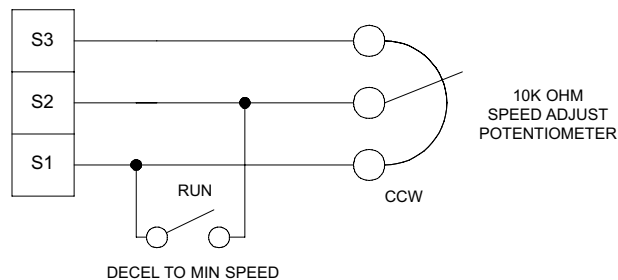

Figure 14. Run/Decelerate to Minimum Speed Switch

Dynamic braking



Warning

Wait for the motor to completely stop before switching it back to RUN. This will prevent high armature currents from damaging the motor or drive.

Dynamic braking may be used to rapidly stop a motor (Figure 15, page 34). The RUN/BRAKE switch must be sized appropriately for braking current. For the dynamic brake resistor, use a high power wirewound resistor.

Dynamic brake resistor value

Sizing the dynamic brake resistor depends on load inertia, motor voltage, and braking time. Use a lower ohm-value, higher-wattage dynamic brake resistor to stop a motor more rapidly.

For motors rated 1/17 horsepower and lower, a brake resistor is not necessary since the armature resistance is high enough to stop the motor without demagnetization. Replace the dynamic brake with 12 gauge wire. See below equations to determine approximate size of dynamic brake resistor.

$$\frac{\text{RATED MOTOR VOLTAGE}}{2 \times \text{RATED MOTOR CURRENT}} = \text{TOTAL RESISTANCE}$$

$$\text{TOTAL RESISTANCE} - \text{ARMATURE RESISTANCE} = \text{DYNAMIC BRAKE RESISTANCE}$$

$$\frac{\text{RATED MOTOR VOLTAGE} \times \text{RATED MOTOR CURRENT}}{20} = \text{RESISTOR WATTAGE (approximately)}$$

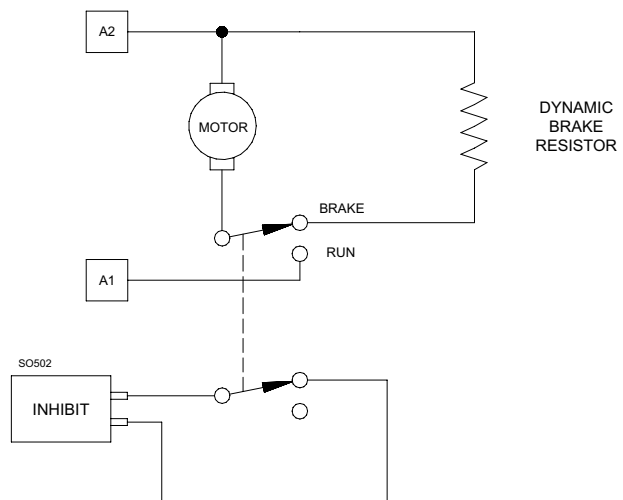

Figure 15. Dynamic Brake Connection

Calibration



Warning

Dangerous voltages exist on the drive when it is powered.

When possible, disconnect the voltage input from the drive before adjusting the trimpots. If the trimpots must be adjusted with power applied, use insulated tools and the appropriate personal protection equipment. **BE ALERT.** High voltages can cause serious or fatal injury.

This series of drives have six user adjustable trimpots: MIN SPD, MAX SPD, ACCEL, DECEL, TORQUE, and IR COMP. Each drive is factory calibrated to its maximum current rating. Readjust the calibration trimpot settings to accommodate lower current rated motors.

All trimpot settings increase with clockwise (CW) rotation, and decrease with counterclockwise (CCW) rotation. Use a non-metallic screwdriver for calibration. Each trimpot is identified on the printed circuit board.

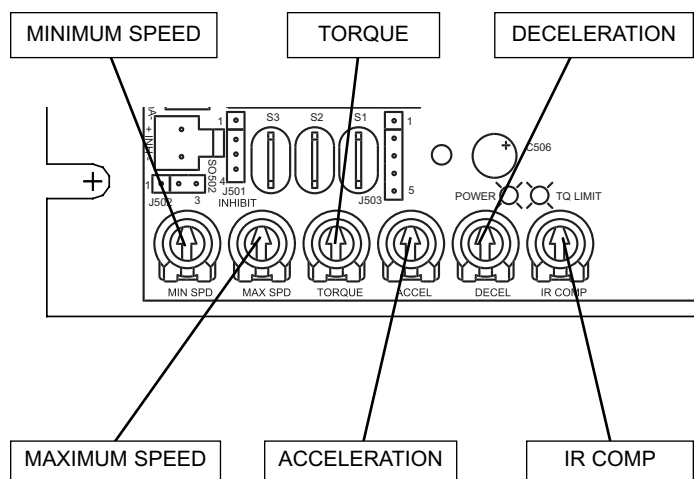

Figure 16. Calibration Trimpot Layout

MIN SPD

The MIN SPD setting determines the motor speed when the speed adjust potentiometer is turned full CCW. It is factory set to zero speed.

Use the following procedure to set MIN SPD:

1. Set the speed adjust potentiometer full CCW.
2. Adjust the MIN SPD trimpot until the motor has stopped (for zero speed setting), or is running at the desired minimum speed.

MAX SPD

The MAX SPD setting determines the motor speed when the speed adjust potentiometer is turned full CW. It is factory set for maximum rated voltage.

Use the following procedure to set MAX SPD:

1. Set the speed adjust potentiometer full CW.
2. Adjust the MAX SPD trimpot until the motor is running at the desired maximum speed.

TORQUE



Warning

TORQUE should be set to 150% of motor nameplate current rating. Continuous operation beyond this rating may damage the motor. If you intend to operate beyond the rating, contact your Bison representative for assistance.

The TORQUE setting determines the maximum torque for accelerating and driving the motor. To calibrate TORQUE refer to the recommended TORQUE settings in Figure 17 on page 43, or use the following procedure:

1. With the power disconnected from the drive, connect a DC ammeter in series with the armature.
2. Set the TORQUE trimpot to minimum (full CCW).
3. Set the speed adjust potentiometer to maximum speed (full CW).
4. Carefully lock the motor armature. Be sure that the motor is firmly mounted.
5. Apply line power. The motor should be stopped.
6. Slowly adjust the TORQUE trimpot CW slowly until the armature current is 150% of motor rated armature current.
7. Turn the speed adjust potentiometer CCW until the motor stops.
8. Remove line power.
9. Remove the stall from the motor.
10. Remove the ammeter in series with the motor armature if it is no longer needed.

IR COMP

The IR COMP trimpot setting determines the degree to which motor speed is held constant as the motor load changes.

Use the following procedure to recalibrate the IR COMP setting:

1. Turn the IR COMP trimpot full CCW.
2. Set the speed adjust potentiometer until the motor runs at midspeed without load (for example, 900 RPM for an 1800 RPM motor) A hand held tachometer may be used to measure motor speed.
3. Load the motor armature to its full load armature current rating. The motor should slow down.
4. While keeping the load on the motor, rotate the IR COMP trimpot until the motor runs at the speed measured in step 2. If the motor does not maintain set speed as the load changes, gradually rotate the IR COMP trimpot CW. If the motor oscillates (overcompensation), the IR COMP trimpot may be set too high (CW). Turn the IR COMP trimpot CCW to stabilize the motor speed.
5. Unload the motor.

See Figure 17 (page 43) for recommended IR COMP settings.

ACCEL

The ACCEL setting determines the time the motor takes to ramp to a higher speed. See Specifications on page 1 for approximate acceleration times. ACCEL is factory set for the fastest acceleration time (full CCW).

Use the following procedure to set the acceleration time:

1. Set the speed adjust potentiometer full CCW. The motor should run at minimum speed (as set by the MIN SPD trimpot, page 37).
2. Turn the speed adjust potentiometer full CW and measure the time it takes the motor to go from minimum to maximum speed.
3. If the time measured in step 2 is not the desired acceleration time, turn the ACCEL trimpot CW for a slower acceleration time, or CCW for a faster acceleration time. Repeat steps 1 through 3 until the acceleration time is correct.

DECEL

The DECEL setting determines the time the motor takes to ramp to a lower speed. See Specifications on page 1 for approximate deceleration times. DECEL is factory set for the fastest deceleration time (full CCW).

Use the following procedure to set the deceleration time:

1. Set the speed adjust potentiometer full CW. The motor should run at maximum speed (as set by MAX SPD trimpot, page 37).
2. Turn the speed adjust potentiometer full CCW and measure the time it takes the motor to go from maximum to minimum speed.
3. If the time measured in step 2 is not the desired deceleration time, turn the DECEL trimpot CW for a slower deceleration time, or CCW for a faster deceleration time. Repeat steps 1 through 3 until the deceleration time is correct.

Torque Mode Calibration

**Warning**

TORQUE and MAX SPD trimpots must be recalibrated every time the drive is switched between Speed and Torque modes.

1. Disconnect power from the drive and connect a DC voltmeter across the armature.
2. Set the MAX SPD and TORQUE trimpots to the 12 o'clock position.
3. Set the external potentiometer to full CW.
4. Apply line power.
5. Adjust the TORQUE trimpot so the motor is running at the motor's maximum rated input voltage (nameplate rating).
6. Remove line power and the DC voltmeter. Be sure the motor is firmly mounted. Connect a DC ammeter in series with the armature. Carefully lock the motor armature.
7. Apply line power.
8. With the external potentiometer set to full CW, slowly adjust the MAX SPD trimpot until the motor draws 100% of the motor's rated armature current (nameplate rating).
9. Remove the line power, stall from motor and ammeter.

Speed Mode Recommended Settings

MODELS 170-103-0002, 170-113-0002, 170-113-0102, and 170-143-0002

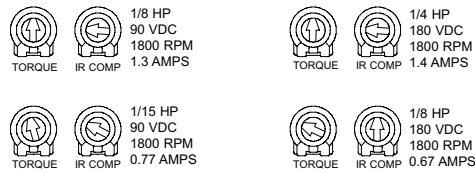

MODELS 170-103-0010, 170-113-0010, 170-113-0110, and 170-143-0010

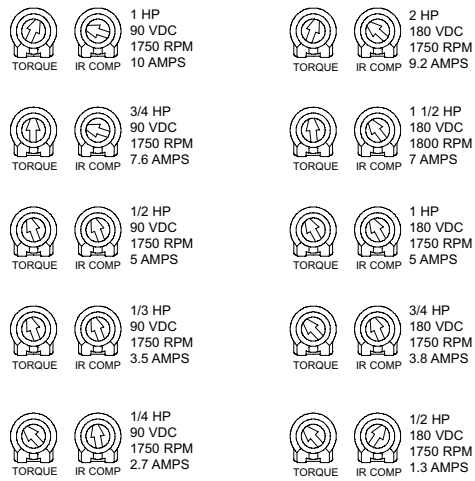

**Figure 17. Recommended Torque and IR COMP Settings
(actual settings may vary with each application)**

Application Notes

Multiple fixed speeds

Replace the speed adjust potentiometer with series resistors with a total series resistance of 5K ohm or 10K ohms (Figure 18). Add a single pole, multi-position switch with the correct number of positions for the desired number of fixed speeds.

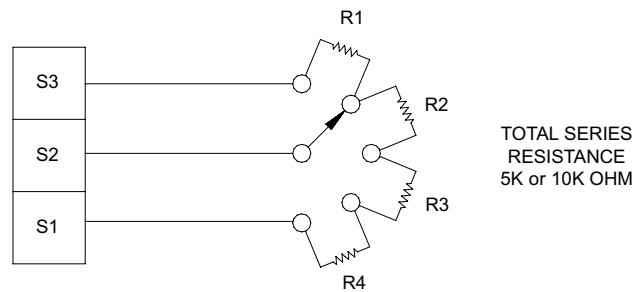

Figure 18. Multiple Fixed Speeds

Adjustable speeds using potentiometers in series

Replace the speed adjust potentiometer with a single-pole, multi-position switch, and two or more potentiometers in series, with a total series resistance of 5K or 10K ohms. Figure 19 shows a connection for fixed high and low speed adjust potentiometers.

The maximum speed adjust trimpot must be recalibrated if this option is selected. Refer to MAX SPD in the **Calibration** section (page 37) for more information.

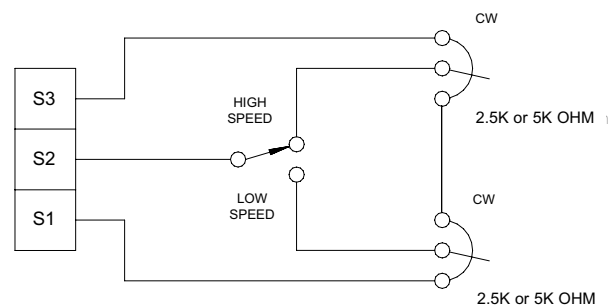

Figure 19. Adjustable Fixed Speeds Using Potentiometers in Series

Independent adjustable speeds

Replace the speed adjust potentiometer with a single pole, multi-position switch, and two or more potentiometers in parallel, with a total parallel resistance of 5K or 10K ohms. Figure 20 shows the connection of two independent speed adjust potentiometers that can be mounted at two separate operating stations.

The maximum speed adjust trimpot must be recalibrated if this option is selected. Refer to MAX SPD in the **Calibration** section (page 37) for more information.

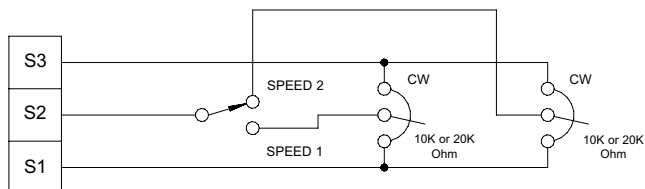

Figure 20. Independent Adjustable Speeds

RUN / JOG switch

Using a RUN / JOG switch is recommended in applications where quick stopping is not needed and frequent jogging is required. Use a single pole, two position switch for the RUN / JOG switch, and a single pole, normally closed, momentary operated pushbutton for the JOG pushbutton.

In the first wiring option, connect the RUN / JOG switch and JOG pushbutton to the inhibit plug as shown in Figure 21. The motor coasts to a stop when the RUN / JOG switch is set to JOG. Press the JOG pushbutton to jog the motor. Return the RUN / JOG switch to RUN for normal operation.

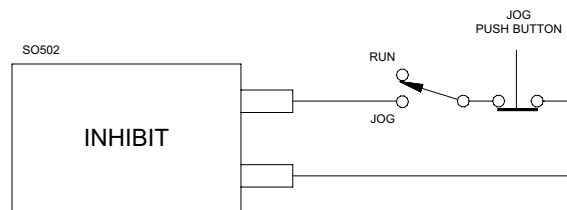

Figure 21. RUN / JOG Switch Connection to Inhibit Plug

In the second wiring option, connect the RUN / JOG switch and the JOG pushbutton as shown in Figure 22. When the RUN / JOG switch is set to JOG, the motor decelerates to minimum speed (minimum speed is determined by the MIN SPD trimpot setting). Press the JOG pushbutton to jog the motor. Return the RUN / JOG switch to RUN for normal operation.

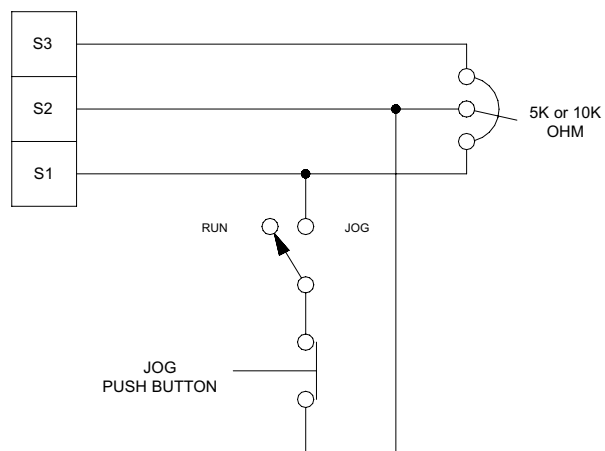

Figure 22. RUN / JOG Switch Connection to Speed Adjust Potentiometer

Leader-follower application

In a leader-follower application, use a 170-993-0200 to monitor the speed of the leader motor (Figure 23). The 170-993-0200 isolates the leader motor from the follower drive, and outputs a voltage proportional to the leader motor armature voltage. The follower drive uses this voltage reference to set the speed of the follower motor. An optional ratio potentiometer may be used to scale the 170-993-0200 output voltage.

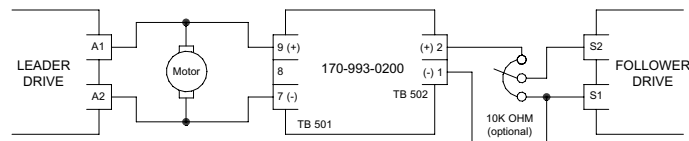

Figure 23. Leader-Follower Application

Single speed potentiometer control of multiple drives

Multiple drives can be controlled with a single speed adjust potentiometer using a 170-993-0200 at the input of each drive to provide isolation (Figure 24). Optional ratio potentiometers can be used to scale the 170-993-0200 output voltage, allowing independent control of each drive.

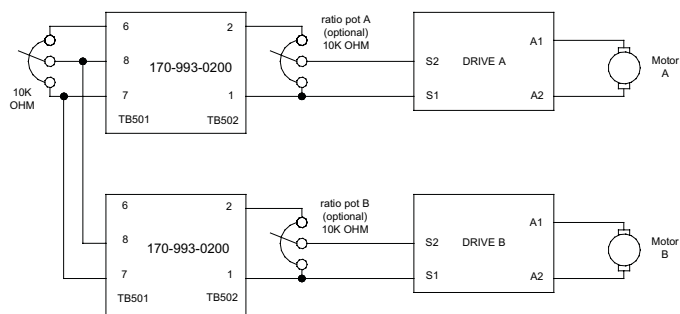

Figure 24. Single Speed Potentiometer Control of Multiple Drives

Reversing

A dynamic brake may be used when reversing the motor direction (Figure 25). Use a three pole, three position switch rated for at least the maximum DC armature voltage and maximum braking current. Wait for the motor to stop completely before switching it to either the forward or reverse direction. See the Dynamic braking section, page 33, for recommended dynamic brake resistor sizes

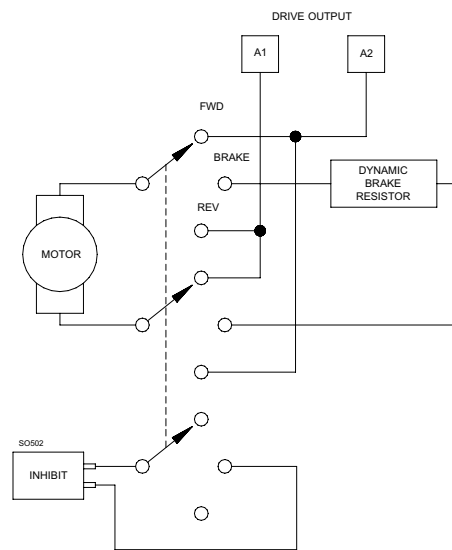

Figure 25. Reversing Circuit Connection

Troubleshooting



Warning

Dangerous voltages exist on the drive when it is powered.

When possible, disconnect the drive while troubleshooting.

High voltages can cause serious or fatal injury.

Before troubleshooting

Perform the following steps before starting any procedure in this section:

1. Disconnect AC line voltage from the drive.
2. Check the drive closely for damaged components.
3. Check that no conductive or other foreign material has become lodged on the printed circuit board.
4. Verify that every connection is correct and in good condition.
5. Verify that there are no short circuits or grounded connections.
6. Check that the voltage selection switch settings match the AC line and output voltages.
7. Check that the drive's rated armature output is consistent with the motor ratings.

For additional assistance, contact your local Bison distributor, or the factory direct by telephone at: 1-800-AT-BISON

Diagnostic LEDs

This series of drives are equipped with two diagnostic LEDs. Refer to Figure 26 for LED location.

Power (PWR):

Lights whenever the AC line voltage is applied to the drive.

Current Limit (CURR LIMIT or CL):

Lights whenever the drive reaches current limit.

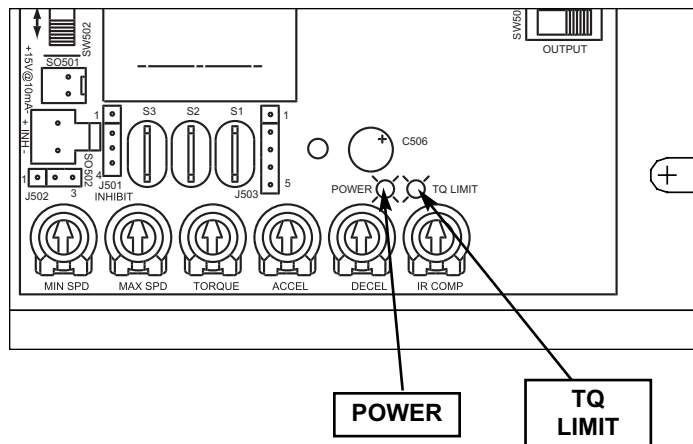

Figure 26. Diagnostic LED Locations

Problem	Possible Causes	Suggested Solutions
Line fuse blows.	<ol style="list-style-type: none"><li data-bbox="706 709 915 751">1. Line fuse is the wrong size.<li data-bbox="706 793 915 856">2. Motor cable or armature is shorted to ground.<li data-bbox="706 877 915 1003">3. Nuisance tripping caused by a combination of ambient conditions and high-current spikes (i.e. reversing).	<ol style="list-style-type: none"><li data-bbox="938 709 1138 772">1. Check that the line fuse is correct for the motor size.<li data-bbox="938 793 1138 835">2. Check motor cable and armature for shorts.<li data-bbox="938 877 1138 1066">3. Add a blower to cool the drive components; decrease TORQUE settings, or resize motor and drive for actual load demand, or check for incorrectly aligned mechanical components or "jams".

Problem	Possible Causes	Suggested Solutions
Line fuse does not blow, but the motor does not run.	<ol style="list-style-type: none"> 1. Speed adjust potentiometer is set to zero speed. 2. INHIBIT terminals are jumpered. 3. S2 is shorted to S1. 4. Drive is in current limit. 5. Drive is not receiving AC line voltage. 6. Motor is not connected. 	<ol style="list-style-type: none"> 1. Increase the speed adjust potentiometer setting. 2. Remove jumper from the INHIBIT terminals. 3. Remove short. 4. Verify that motor is not jammed. Increase TORQUE setting if they are set too low. 5. Apply AC line voltage to L1 and L2. 6. Connect motor to A1 and A2.
Motor does not stop when the speed adjust potentiometer is full CCW.	<ol style="list-style-type: none"> 1. MIN SPD setting is too high. 	<ol style="list-style-type: none"> 1. Calibrate MIN SPD.
Motor runs in the opposite direction (non-reversing drives).	<ol style="list-style-type: none"> 1. Motor connections to A1 and A2 are reversed. 	<ol style="list-style-type: none"> 1. Reverse connections to A1 and A2.

Problem	Possible Causes	Suggested Solutions
Motor runs too fast.	1. MAX SPD and MIN SPD are set too high.	1. Calibrate MAX SPD and MIN SPD.
Motor will not reach the desired speed.	1. MAX SPD setting is too low. 2. IR COMP setting is too low. 3. TORQUE setting is too low. 4. Motor is overloaded.	1. Increase MAX SPD setting. 2. Increase IR COMP setting. 3. Increase TORQUE setting. 4. Check motor load. Resize the motor if necessary.
Motor pulsates or surges under load.	1. IR COMP is set too high. 2. Motor bouncing in and out of current limit.	1. Adjust the IR COMP setting slightly CCW until the motor speed stabilizes. 2. Make sure motor is not undersized for load; adjust TORQUE trimpot CW.

Functional Diagrams

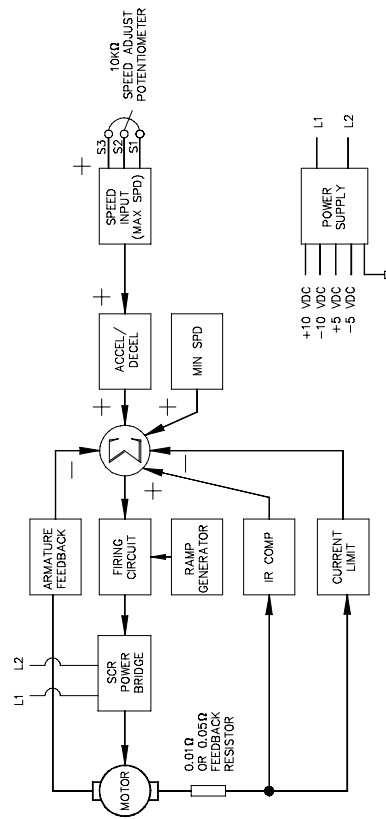

Figure 27. Block Diagram

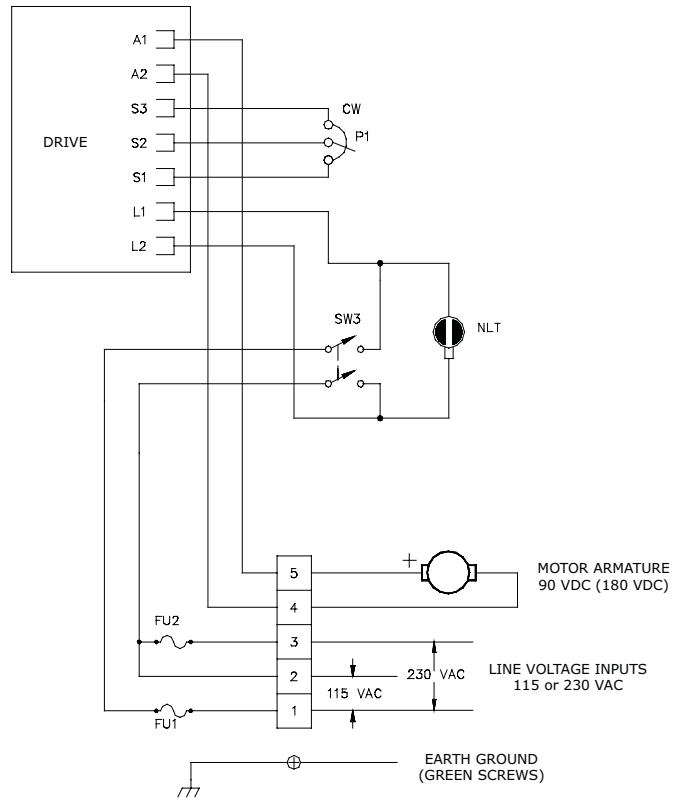

Figure 28. 170-113-0010, 170-113-0002, 170-143-0010 and 170-143-0002 Terminal Block Connections

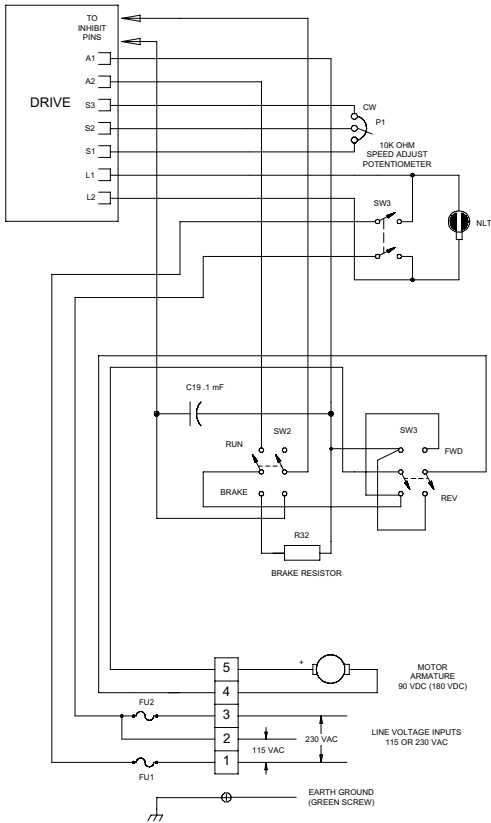

Figure 29. 170-113-0110 and 170-113-0102 Terminal Block Connections

Certificate of Compliance

Bison hereby certifies that this series of drives has been approved to bear the “CE” mark provided the conditions of approval have been met by the end user.

This series has been tested to the following test specifications:

**EN55011:1991 (emissions), and
EN50082-1:1992 (immunity)**

Compliance allows this series of drives to bear the CE mark.

The end user, as described herein, falls into one of two categories:

1. The Consumer will deploy a stand-alone unit as an integral, yet external, portion of the machine being operated.
2. The Original Equipment Manufacturer (OEM) will implement the product as a component of the machine being manufactured.

In addition to EMI/RFI safeguards inherent in this series design, external filtering is required.

Line filters

Bison requires the Corcom® line filters listed below.

Table 2. Corcom® Filters

Nameplate Current of Motor Wired to the Drive	Corcom® Filter Part Number
0 to 4 amps	6VV1
4.1 to 13 amps	20VV1

The line filters should be wired to the AC line within 0.25 meters of the drive. The ground connection from the line filter must be wired to solid earth ground (resistance less than 500 ohms); not machine ground. This is very important!

If the end-user is using a CE-approved motor, the correct line filter listed above is all that is necessary to meet the EMC directives listed herein.

The end user must use the filters listed in this section to comply with CE. The OEM may choose to provide alternative filtering that encompasses the Bison drive and other electronics within the same panel.

The OEM has this liberty because CE is a machinery directive. Whether or not every component in the OEM's machinery meets CE, the OEM must still submit his machine for CE approval.

Thus, no component must necessarily meet CE within the machine, as long as the OEM takes the necessary steps to guarantee the machine does meet CE. By the same token, even if every component in the OEM's machine does meet CE, the machine will not necessarily meet CE as a machine.

Using CE-approved wiring practices (such as proper shielding) and the filters listed in this section help the drive meet EN55011 (1991 emissions standard) and EN50082-1 (1992 immunity standard).

Notes

Notes

Bison Warranty Policy

The Company warrants to the Buyer the products sold hereunder to be free of defects in material and workmanship under normal use and service for a period of one (1) year from the date of shipment. The obligation of the Company under this warranty is limited to repair or replacing at its option, any part or parts, which upon examination shall disclose to the reasonable satisfaction of the Company to have been defective in material or workmanship. Buyer must return the products to the Company's factory, shipping charges prepaid, and with complete information as to alleged defects and the installation, operation and service of the products. Except as otherwise expressly stated herein the Company makes no representation of warranty of any kind, express or implied, as to merchantability, fitness for a particular purpose, or any other matter with respect to the products sold hereunder.



Bison Gear & Engineering Corp.
3850 Ohio Ave. -- St. Charles, IL 60174
Phone: 1-800-AT-BISON
www.bisongear.com

Document Number: 250-0414; Revision 0 -- June 2006