

56C, 56J and Square Flange Mechanical Dimensions

Features

Dimensions

Drip-proof, Totally Enclosed Fan Cooled and Explosion Proof. All dimensions are approximate, not to be used for construction purposes.
 Note: Drawing shows rigid base. Foot mounting dimensions listed are identical for either rigid or resilient base mounting. For 56H Combination Foot, refer to Diagram 1. For C Flange motors, refer to Diagram 2.

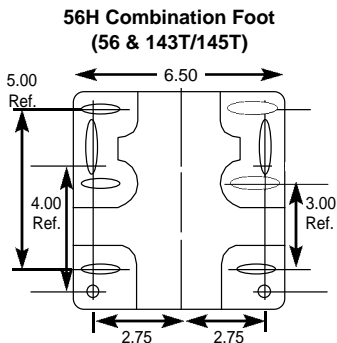

Diagram 1

Suffix "Y" = Special Mount Dim.
 Suffix "Z" = Special Shaft Dim.

Common to All Squirrel Cage Motors

Frame	D	E	F	BA	U	N-W	Key Size
42	2-5/8	1-3/4	27/32	2-1/16	3/8	1-1/8	.05 Flat
48	3	2-1/8	1-3/8	2-1/2	1/2	1-5/8	.05 Flat
56	3-1/2	2-7/16	1-1/2	2-3/4	5/8	1-7/8	3/16 sq. x 1-3/8
56H	3-1/2	Dia. 1	Dia. 1	2-3/4	5/8	1-7/8	3/16 sq. x 1-3/8
56C	See Diagram 2				5/8	1-7/8	3/16 sq. x 1-3/8
56J	See Diagram 2				5/8	2-7/16	Threaded
143T	3-1/2	2-3/4	2	2-1/4	7/8	2-1/4	3/16 sq. x 1-3/8
145T	3-1/2	2-3/4	2-1/2	2-1/4	7/8	2-1/4	3/16 sq. x 1-3/8

CONVERSION CHART

Decimal	Fraction
0.0313	1/32
0.0625	1/16
0.0938	3/32
0.1250	1/8
0.1563	5/32
0.1875	3/16
0.2188	7/32
0.2500	1/4
0.2813	9/32
0.3125	5/16
0.3438	11/32
0.3750	3/8
0.4063	13/32
0.4375	7/16
0.4688	15/32
0.5000	1/2
0.5313	17/32
0.5625	9/16
0.5938	19/32
0.6250	5/8
0.6563	21/32
0.6875	11/16
0.7188	23/32
0.7500	3/4
0.7813	25/32
0.8125	13/16
0.8438	27/32
0.8750	7/8
0.9063	29/32
0.9375	15/16
0.9688	31/32

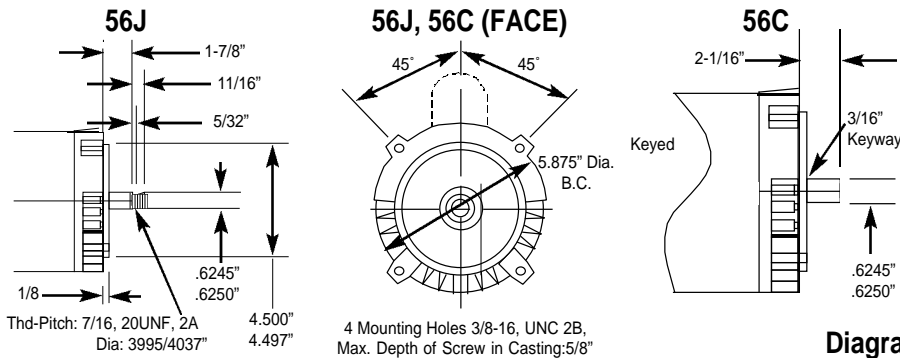

Diagram 2

SQUARE FLANGE

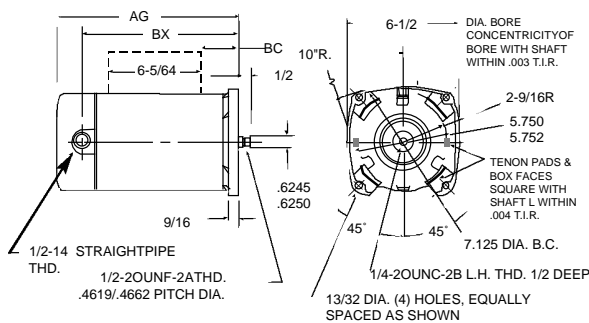

Diagram 3