

TYPE	FRAME SIZE
CX	J56Z

REV	ECO	REV BY	DATE	APPD	DATE
G	0039276	F.NAVARRO	10-10-2013	T.REYES	10-10-2013

- NOTES:
1. RUNOUT MUST NOT EXCEED .005[.125] T.I.R. WHEN MEASURED 1.0[25] INCH FROM END OF SHAFT.
 2. SHAFT AND BASE TO BE PARALLEL +/- .0625[1.588] WHEN MEASURED 1.0[25] INCH FROM END OF SHAFT.

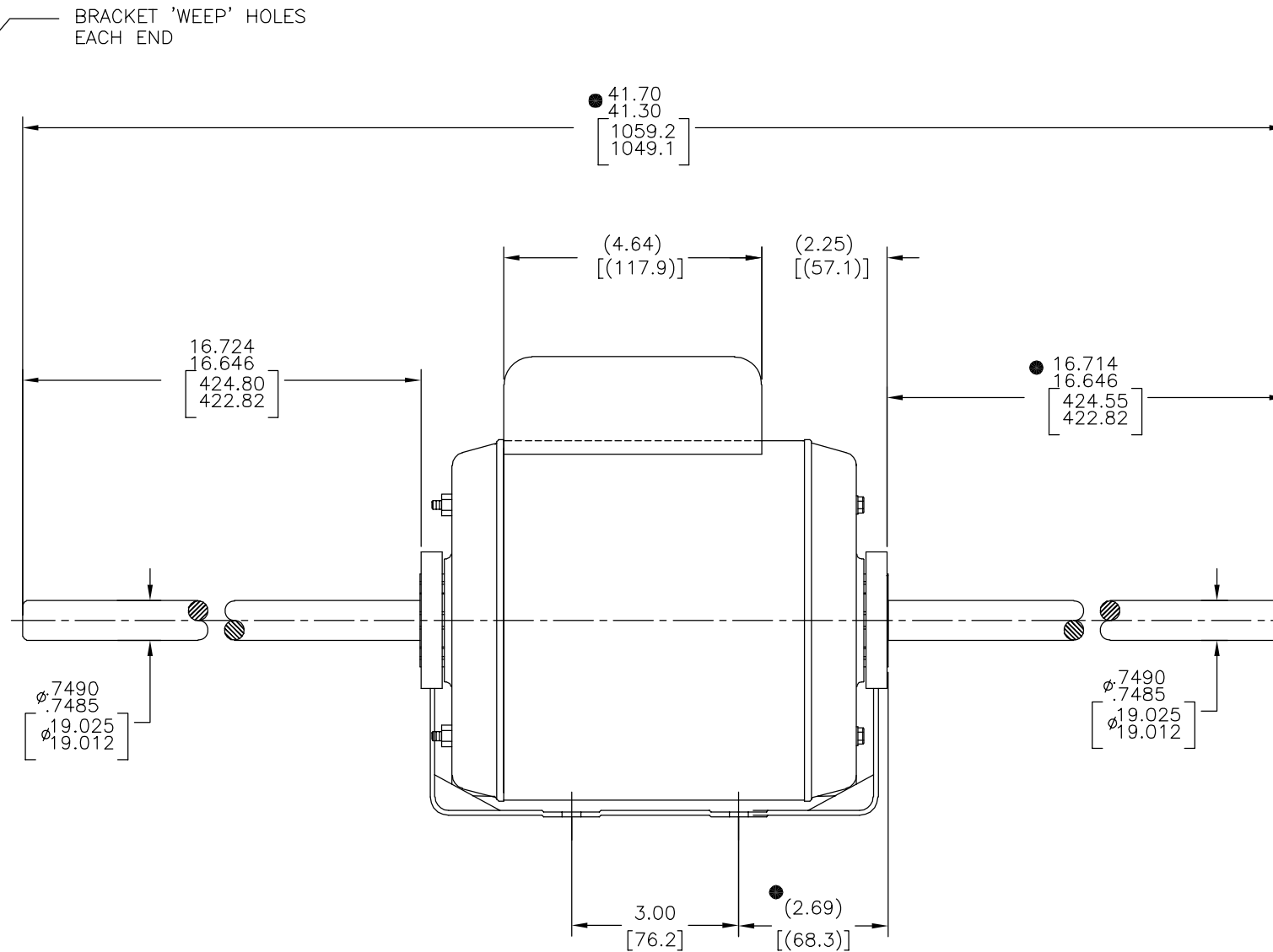
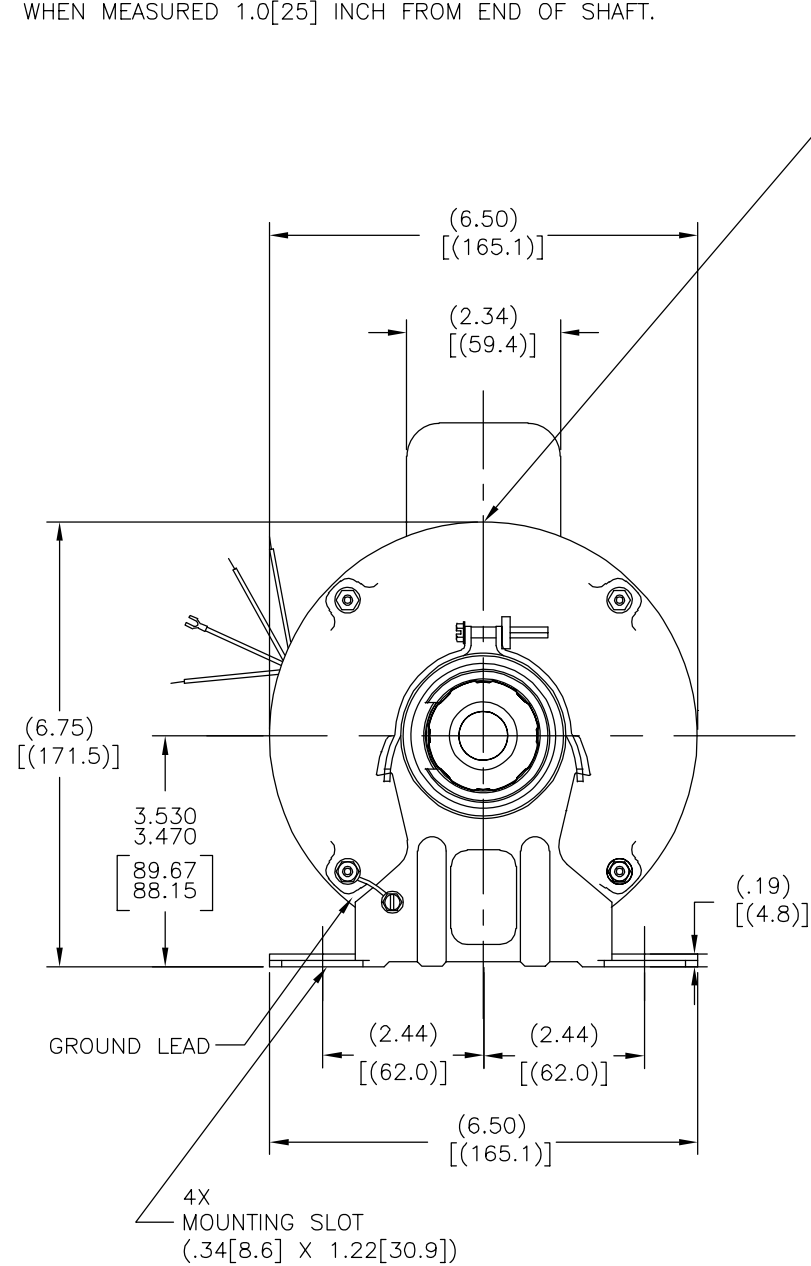

GEOMETRIC CHARACTERISTICS & SYMBOLS

- ▭ FLATNESS
- STRAIGHTNESS
- ∠ ANGULARITY
- ⊥ PERPENDICULARITY (SQUARENESS)
- ∥ PARALLELISM
- ROUNDNESS (CIRCULARITY)
- ⊘ CYLINDRICITY
- △ PROFILE OF ANY SURFACE
- ∩ PROFILE OF ANY LINE
- ↗ RUNOUT
- ⊕ TRUE POSITION
- ◎ CONCENTRICITY
- ≡ SYMMETRY

ASME Y14.5M 1994

UNLESS OTHERWISE SPECIFIED DIM. TOLERANCES ARE AS FOLLOWS:

INCH	X	XX	XXX	XXXX
	±.1	±.02	±.005	±.0005
mm	±0.5	±0.13	±0.013	

ANG. ±.50 DEG
REMOVE BURRS & BREAK SHARP EDGES:
INCH .003-.015 mm 0.1-0.4
CORNER FILLETS TO:
INCH .020 mm 0.5
MACHINE SURFACES:
INCH 125 mm 3.2

METRIC DIMS. SHOWN IN [BRACKETS]

DR BY:	SVR	10-16-1996
APPD:	SAS	10-18-1996
THIRD ANGLE PROJECTION		EDS DATE 11-11-2011 FORMAT REV H
CONFIDENTIAL: THIS DRAWING AND ITS INFORMATION ARE THE EXCLUSIVE AND CONFIDENTIAL PROPERTY OF REGAL-BELOIT CORPORATION AND ARE NOT TO BE DISCLOSED, DUPLICATED, DISTRIBUTED OR OTHERWISE USED WITHOUT THE WRITTEN CONSENT OF REGAL-BELOIT CORPORATION. -ALL RIGHTS RESERVED.		

REGAL-BELOIT CORPORATION	
DESCRIPTION MODEL-CFHP-56FR OUTLINE	
SIZE C	DWG NO C031
SCALE NONE	SHEET 1

TIPO	TAMAÑO DE CARCASA
CX	J56Z

REVISION:	ECO	REVISADO POR:	FECHA:	APROBADO POR:	FECHA:
G	0039276	F.NAVARRO	10-10-2013	T.REYES	10-10-2013

- NOTAS:
1. LA OSCILACION DEL INDICADOR NO DEBE EXCEDER .005[.125] L.T.I. CUANDO MIDE 1.0[25] DE PULGADA DE LADO DE FLECHA.
 2. LA FLECHA Y BASE DEBEN SER PARALELAS +/- .0625[1.588] CUANDO MIDE 1.0[25] DE PULGADA DE LADO DE FLECHA.

ORIFICIOS DE SUPURACION DE LA TAPA EN CADA LADO

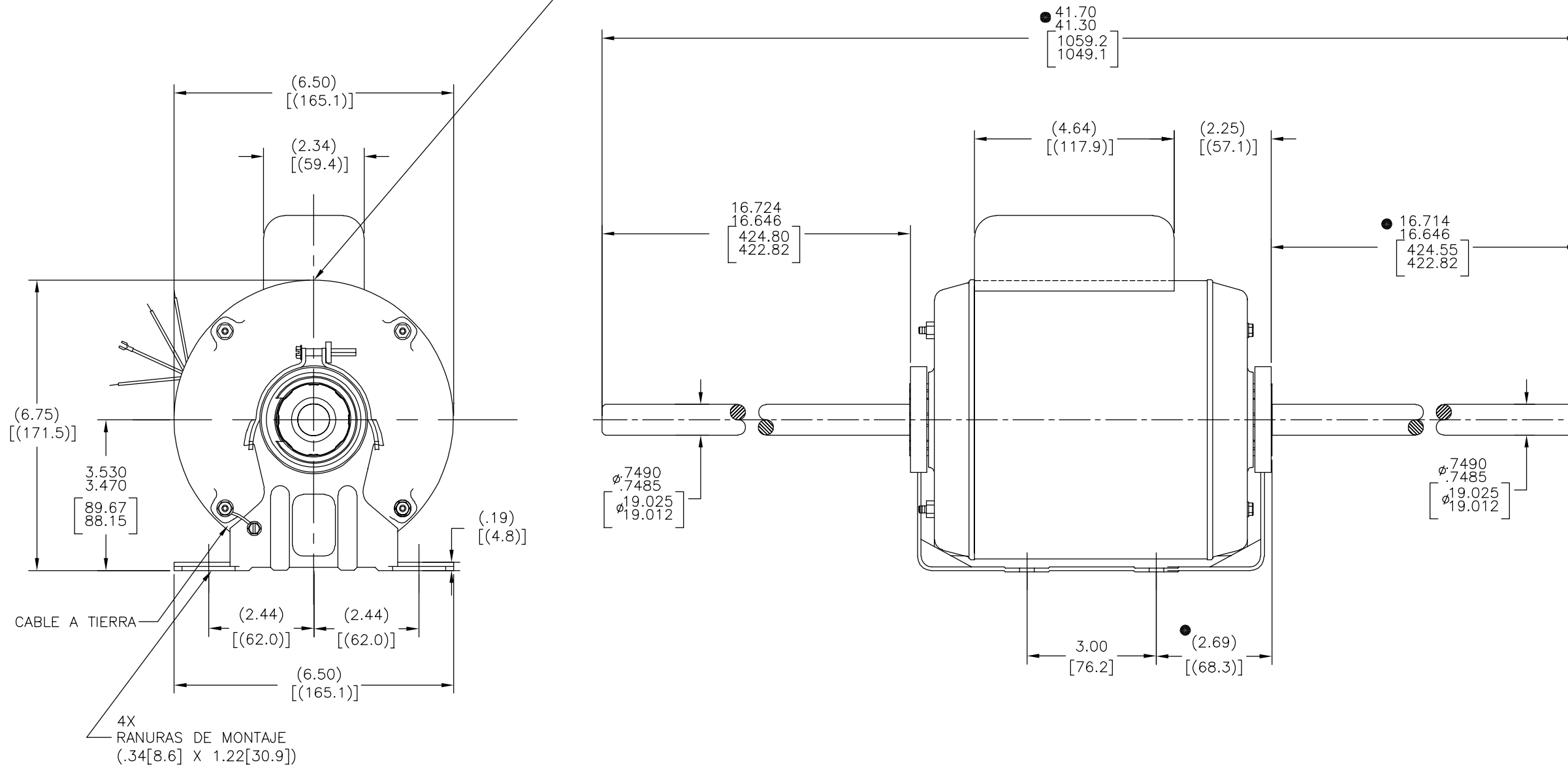

CABLE A TIERRA

4X RANURAS DE MONTAJE
(.34[8.6] X 1.22[30.9])

CARACTERISTICAS DE GEOMETRIA Y SIMBOLOS

- ▭ PLANICIDAD
- RECTITUD
- ∠ ANGULARIDAD
- ⊥ PERPENDICULARIDAD (A ESCUADRA)
- // PARALELISMO
- REDONDEZ (CIRCULARIDAD)
- ∅ CILINDRICIDAD
- △ PERFIL DE CUALQUIER SUPERFICIE
- ∧ PERFIL DE CUALQUIER LINEA
- ∓ VARIACION
- ⊕ POSICION REAL
- ◎ CONCENTRICIDAD
- = SIMETRIA

ASME Y14.5M 1994

A MENOS QUE SE ESPECIFIQUE DE OTRA MANERA, LAS TOLERANCIAS DE LAS DIMS; SON LAS SIGUIENTES:

	PULG	±.1	±.02	±.005	±.0005
	mm	±0.5	±0.13	±0.013	

ANG. ± 50 GRADOS
ELIMINAR REBABAS Y ORILLAS FILOSAS DEL BORDE.
PULG .003-.015 mm 0.1-0.4
FILETEAR ESQUINA: PULG .020 mm 0.5
MAQUINAR SUPERFICIES
PULG 125 mm 3.2

DIMS METRICAS MOSTRADAS [PARENTESIS]

DIBUJADO POR:	SVR	10-16-1996
APROBADO POR:	SAS	10-18-1996
TERCER ANGULO DE PROYECCION	⊕	FECHA EDS: 11-11-2011 REV. FORMATO: H

CONFIDENCIAL: ESTE DIBUJO Y SU INFORMACION SON PROPIEDAD DE USO EXCLUSIVO Y CONFIDENCIAL DE REGAL-BELOIT CORPORATION. Y NO DEBERAN SER REVELADOS, DUPLICADOS, DISTRIBUIDOS O USARSE DE OTRA MANERA SIN EL CONSENTIMIENTO ESCRITO DE REGAL-BELOIT CORPORATION. -TODOS LOS DERECHOS RESERVADOS.

REGAL REGAL-BELOIT CORPORATION	
DESCRIPCION: MODEL-CFHP-56FR OUTLINE	
TAMAÑO: C	NUMERO DE DIBUJO: C031
ESCALA: NONE	HOJA: 1