

4

3

2

1

TYPE	FRAME
CX	J56Z

REV	ECO	REV BY	DATE	APPD	DATE
B	0024901	H.ZHANG	03-19-2012	B.SHEN	03-19-2012

NOTES:

RUN OUT MUST NOT EXCEED .005 [.13] T.I.R.
WHEN MEASURED 1.0 [25] INCH FROM END OF SHAFT.

SHAFT AND BASE TO BE PARALLEL +/- .0625 [1.588]
WHEN MEASURED 1.0 [25] INCH FROM END OF SHAFT.

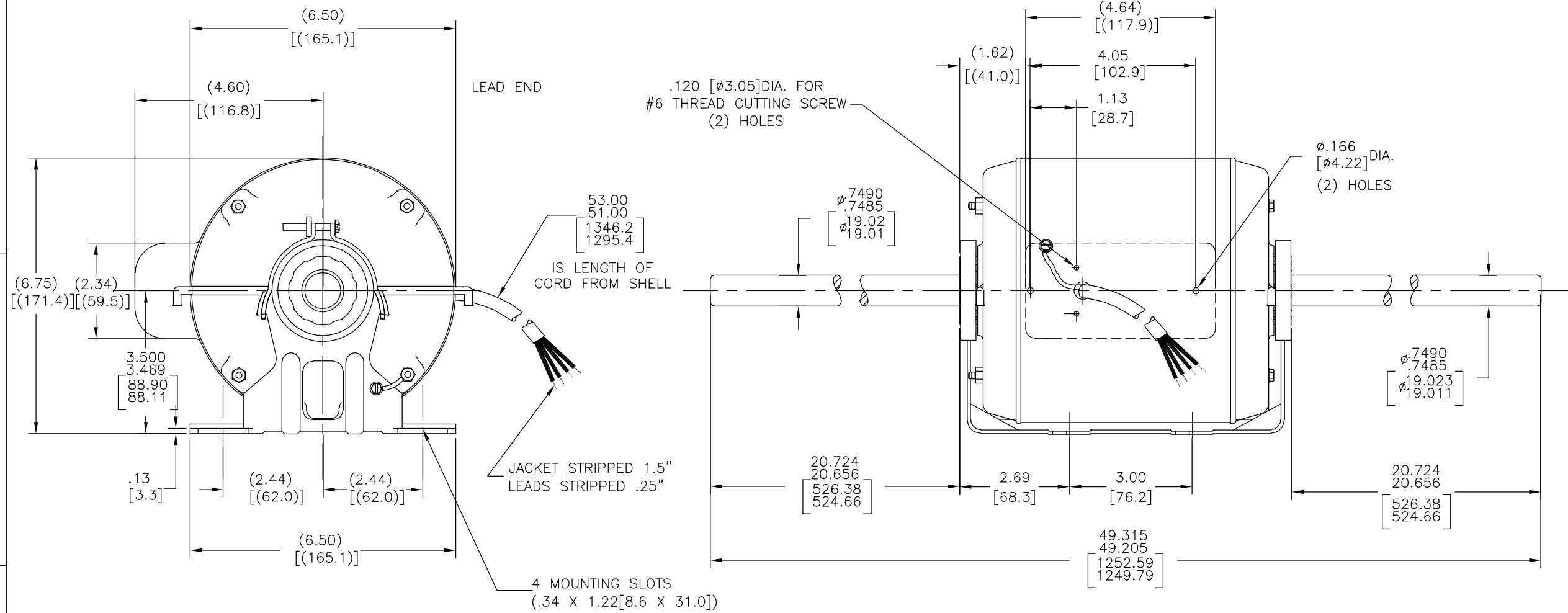

GEOMETRIC CHARACTERISTICS & SYMBOLS

- ▭ FLATNESS
- STRAIGHTNESS
- ∠ ANGULARITY
- ⊥ PERPENDICULARITY (SQUARENESS)
- // PARALLELISM
- ROUNDNESS (CIRCULARITY)
- ⊘ CYLINDRICITY
- △ PROFILE OF ANY SURFACE
- ∩ PROFILE OF ANY LINE
- ↗ RUNOUT
- ⊕ TRUE POSITION
- ⊙ CONCENTRICITY
- ≡ SYMMETRY

ASME Y14.5M 1994

UNLESS OTHERWISE SPECIFIED
DIM. TOLERANCES ARE AS FOLLOWS:

INCH	±.1	±.02	±.005	±.0005
mm	±0.5	±0.13	±0.013	

ANG. ±.50 DEG
REMOVE BURRS & BREAK SHARP EDGES:
INCH .003-.015 mm 0.1-0.4
CORNER FILLETS TO:
INCH .020 mm 0.5
MACHINE SURFACES:
INCH 125 mm 3.2

METRIC DIMS. SHOWN IN [BRACKETS]

DR BY: BARPEA 08-11-2000

APPD:

THIRD ANGLE PROJECTION

EDS DATE 11-11-2011
FORMAT REV G

CONFIDENTIAL: THIS DRAWING AND ITS INFORMATION ARE THE EXCLUSIVE AND CONFIDENTIAL PROPERTY OF REGAL-BELOIT CORPORATION AND ARE NOT TO BE DISCLOSED, DUPLICATED, DISTRIBUTED OR OTHERWISE USED WITHOUT THE WRITTEN CONSENT OF REGAL-BELOIT CORPORATION. -ALL RIGHTS RESERVED.

REGAL-BELOIT CORPORATION

DESCRIPTION
0056 SWG 0-LINE SB ENCL

SIZE C DWG NO C035

SCALE NONE SHEET 1

4

3

2

1

4

3

2

1

REVISION:	ECO	REVISADO POR:	FECHA:	APROBADO POR:	FECHA:
B	0024901	H.ZHANG	03-19-2012	B.SHEN	03-19-2012

CX	J56Z
----	------

D

D

C

C

B

B

A

A

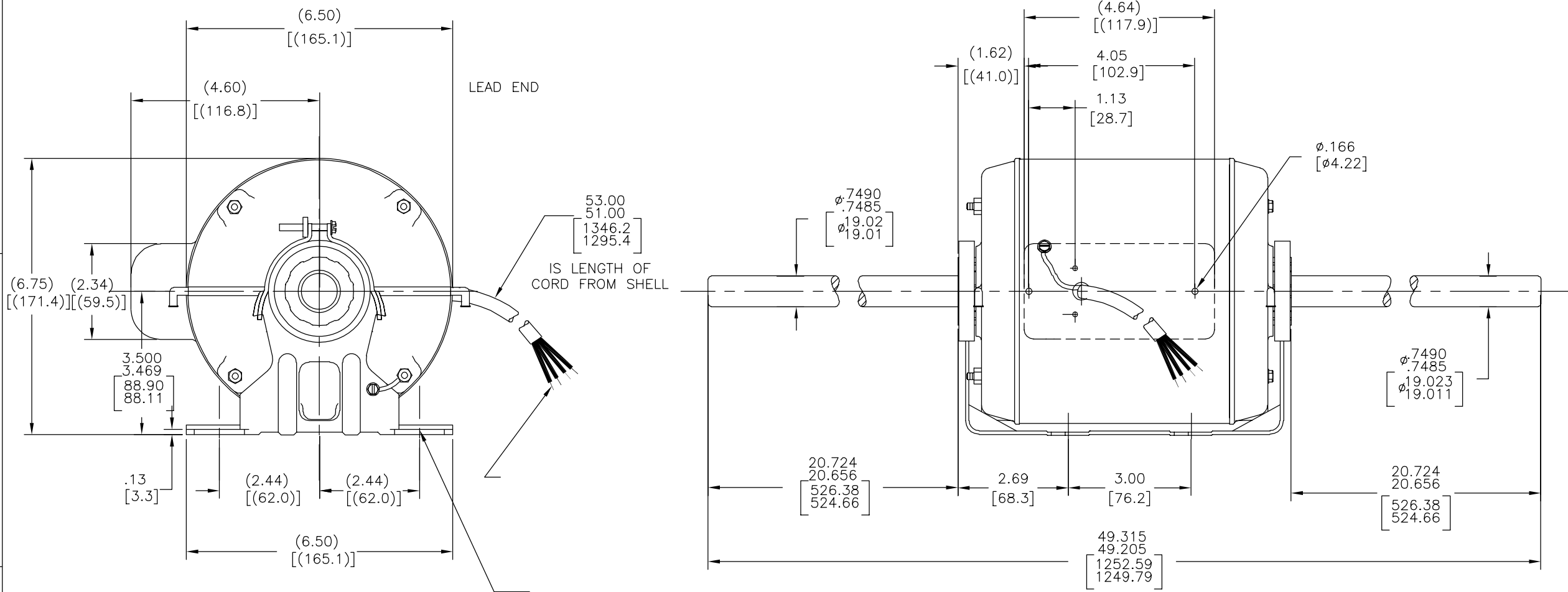

CARACTERISTICAS DE GEOMETRIA Y SIMBOLOS

- ▧ PLANICIDAD
- RECTITUD
- ∠ ANGULARIDAD
- ⊥ PERPENDICULARIDAD (A ESQUADRA)
- // PARALELISMO
- REDONDEZ (CIRCULARIDAD)
- ∅ CILINDRICIDAD
- △ PERFIL DE CUALQUIER SUPERFICIE
- ∧ PERFIL DE CUALQUIER LINEA
- ∧ VARIACION
- ⊕ POSICION REAL
- ⊙ CONCENTRICIDAD
- = SIMETRIA

ASME Y14.5M 1994

A MENOS QUE SE ESPECIFIQUE DE OTRA MANERA, LAS TOLERANCIAS DE LAS DIMS; SON LAS SIGUIENTES:

PULG ±.1 ±.02 ±.005 ±.0005
 mm ±0.5 ±0.13 ±0.013

ANG. ±50 GRADOS

ELIMINAR REBABAS Y ORILLAS FILOSAS DEL BORDE.

PULG .003-.015 mm 0.1-0.4

FILETEAR ESQUINA: PULG .020 mm 0.5

MAQUINAR SUPERFICIES

PULG 125 mm 3.2

DIMS METRICAS MOSTRADAS [PARENTESIS]

DIBUJADO POR: BARPEA 08-11-2000

APROBADO POR:

TERCER ANGULO DE PROYECCION

FECHA EDS: 11-11-2011

REV. FORMATO: G

CONFIDENCIAL: ESTE DIBUJO Y SU INFORMACION SON PROPIEDAD DE USO EXCLUSIVO Y CONFIDENCIAL DE REGAL-BELOIT CORPORATION. Y NO DEBERAN SER REVELADOS, DUPLICADOS, DISTRIBUIDOS O USARSE DE OTRA MANERA SIN EL CONSENTIMIENTO ESCRITO DE REGAL-BELOIT CORPORATION. -TODOS LOS DERECHOS RESERVADOS.

REGAL-BELOIT CORPORATION

DESCRIPCION: 0056 SWG 0-LINE SB ENCL

TAMAÑO: C NUMERO DE DIBUJO: C035

ESCALA: NONE HOJA: 1

4

3

2

1

4

3

2

1

版本	ECO	编制	日期	批准	日期
B	0024901	H.ZHANG	03-19-2012	B.SHEN	03-19-2012

CX	J56Z
----	------

D

D

C

C

B

B

A

A

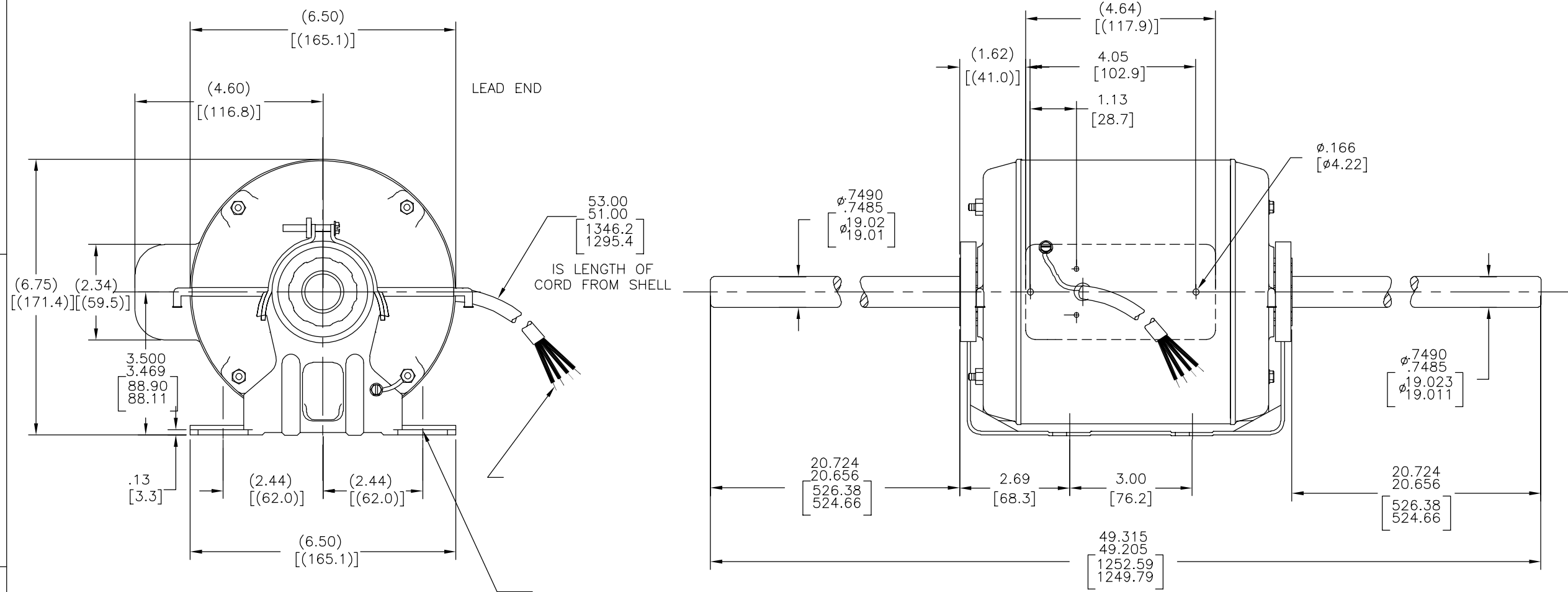

形位公差	除另有注明
□ 平面度	尺寸公差如下:
— 直线度	英寸 X XX XXX XXXX
∠ 倾斜度	英寸 ±.1 ±.02 ±.005 ±.0005
⊥ 垂直度	毫米 ±0.5 ±0.13 ±0.013
// 平行度	角度 ±.50 度
○ 圆度	清理毛刺和尖棱
⊘ 圆柱度	英寸 .003-.015 毫米 0.1-0.4
△ 面轮廓度	内圆角
∩ 线轮廓度	英寸 .020 毫米 0.5
↗ 圆跳动	表面粗糙度
⊕ 位置度	英制 125 米制 3.2
⊙ 同轴度	米制尺寸显示在 []
≡ 对称度	

ASME Y14.5M 1994

绘图:	BARPEA	08-11-2000
批准:		
第三角投影		图纸格式发布日期 11-11-2011 图纸格式版本 G
机密: 本图纸及相关信息所有权归REGAL-BELOIT CORPORATION 未经REGAL-BELOIT CORPORATION书面授权, 不得泄露、 复制、传播或作其他用途。—版权所有		



名称	0056 SWG 0-LINE SB ENCL	
图幅	C	图号 C035
比例	NONE	页号 1

4

3

2

1