

.19 SQ. x 1.38 KEY

MANUAL OVERLOAD WITH BUTTON COVER

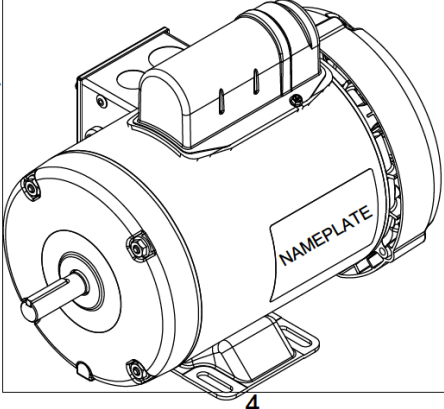
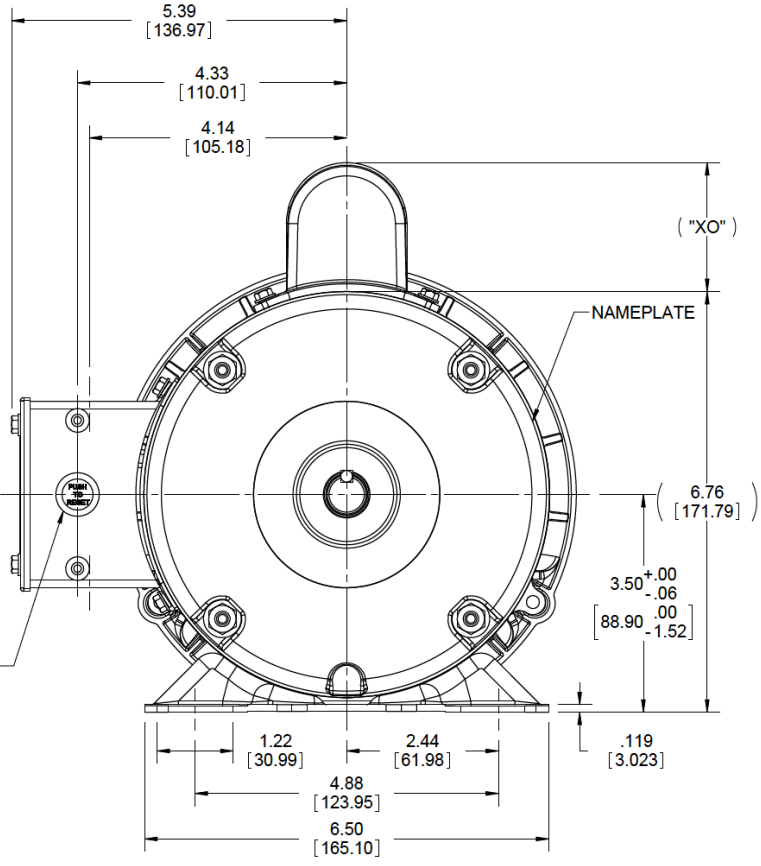

DASH NO	"C"	"AD"	CAP	"XO"
500	10.48	2.13	CAP	"XO"
550	10.98	2.63	DASH	
600	11.48	3.13	A	1.61
650	11.98	3.63	B	2.08
700	12.48	4.13	C	2.32

NOTES:  
1) GASKETS THROUGHOUT

ORACLE REV	02
------------	----

DRAWING REVISION D	REVISION BY M. MCCAULEB	DATE 8/4/14
ECO ECO-0056788	APPROVED BY G. SCHALLOCK	DATE 8/4/14
ECO DESCRIPTION ADDED T-BOLT NUTS		
<small>COPYRIGHT REGAL BELOIT AMERICA, INC. ALL RIGHTS RESERVED.                  PROPRIETARY AND CONFIDENTIAL INFORMATION- THIS DOCUMENT IS THE PROPERTY OF                  REGAL BELOIT AMERICA, INC. (OWNER) AND CONTAINS OWNERS PROPRIETARY                  INFORMATION. ANY PERSON, CORPORATION OR OTHER FIRM RECEIVING IT IS DEEMED,                  BY RECEIVING IT, TO AGREE THAT IT, AND/OR ANY PART OF IT, SHALL NOT BE DISCLOSED                  TO ANY PERSON, CORPORATION OR OTHER ENTITY, DUPLICATED, AND/OR USED, EXCEPT                  AS EXPRESSLY APPROVED IN WRITING IN ADVANCE BY OWNER. THIS DOCUMENT SHALL                  BE RETURNED TO OWNER UPON REQUEST. IT MAY BE SUBJECT TO CERTAIN                  RESTRICTIONS UNDER APPLICABLE EXPORT CONTROL LAWS AND REGULATIONS.</small>		

TOLERANCES UNLESS OTHERWISE SPECIFIED:

DEC.	INCH	mm	ANGLE
X	±0.1	[±2.5]	±0.5°
.XX	±0.03	[±0.76]	
.XXX	±0.005	[±0.127]	
.XXXX	±0.0005	[±0.0127]	

REMOVE BURRS & BREAK SHARP  
 EDGES: .003/.015 [076/381]  
 CORNER FILLETS: .02 [51]  
 MACHINED SURFACES: 125/3.2  
 mm SHOWN IN [BRACKETS]

DRAWN BY KMM 09/11/07	DATE
APPROVED BY	DATE
REFERENCE	DATE
THIRD ANGLE PROJECTION	

Regal Beloit America, Inc.	
DESCRIPTION <b>OUTLINE</b> TEFC - RIGID - 56 FRAME	
MATERIAL	PROCESS/FINISH GENERAL PURPOSE
SIZE B	DRAWING NUMBER 028793
SHEET 1 OF 1	

4

3

2

1