

[Back to Super II Pump Page](#)

For Replacement Motors see bottom of page

Super II™

High Performance Pump Series



SP3015X20AZ 2 HP Super II pump.

Designed for even the most demanding installations, Super II simply out-performs all others. Efficient, full-flow hydraulics produce more flow at equivalent horsepower, resulting in lower operating costs. Super II, when you want the very best.

Applications

- In-ground pools of all types and sizes (including in-floor cleaning systems, solar heating systems, water features)
- In-ground spas or in-ground pool/spa combinations
- Fountains

Features

- Self-priming (suction lift up to 8' above water level)
- Easy thread design makes strainer cover removal easy
- Lexan® see-thru strainer cover lets you see when basket needs cleaning
- 180 cubic inch basket has extra leaf-holding capacity. Load-extender ribbing ensures free flowing operation
- All components molded of corrosion-proof PermaGlass XL™ for extra durability and long life
- Heavy-duty, high performance motor for quieter, cooler operation
- Service-ease design gives simple access to all internal parts

Performance Data

		Pump Output (GPM) vs. Total Resistance To Flow (Feet of Head)					
Model No. Max Rated	Model No. Full Rated	40 ft	50 ft	60 ft	70 ft	80 ft	90 ft
SP3005X7AZ	-----	52	43	30	13	-----	-----
SP3007X10AZ	SP3007EEAZ	78	67	56	38	-----	-----
SP3010X15AZ	SP3010EEAZ	96	87	73	60	36	-----
SP3015X20AZ	SP3015EEAZ	118	107	94	79	60	18
SP3020X25AZ	SP3020EEAZ	138	125	112	96	75	43
SP3025X30AZ	SP3025EEAZ	161	150	137	123	106	84
--	SP303063AZ	161	150	137	123	106	84

Performance Data (low speed)

		Pump Output (GPM) vs. Total Resistance To Flow (Feet of Head)		
Model No. Max Rated	5 ft	10 ft	15 ft	
SP3010X152AZ	47	45	32	
SP3015X202AZ	65	57	42	
SP3020X252AZ	71	61	48	

Miscellaneous Notes

10 Year Warranty On Strainer Housing

For high-performance data on dual-speed pumps refer to the Performance Chart.

Overall Dimensions

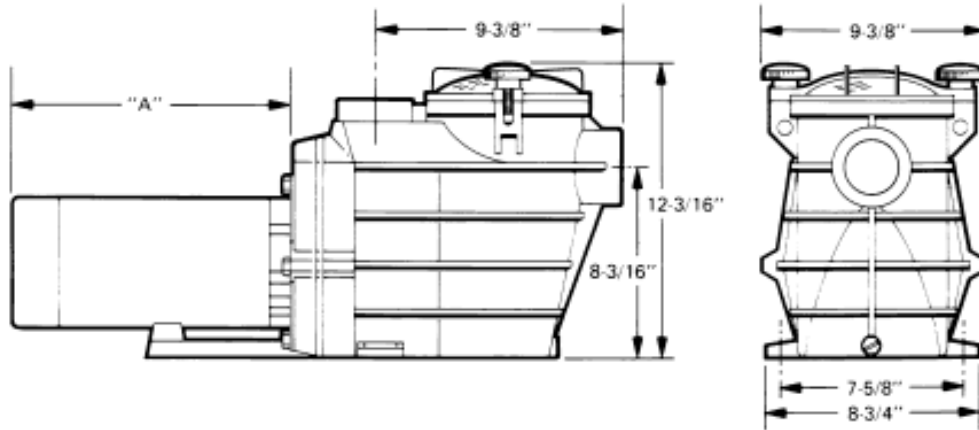

Replacement Motors:

[Super Pumps use the 56J Motor](#)

Seal = AS201

Electric Motor Warehouse
1-877-98MOTOR

© 2001 Hayward Pool Products, Inc.