



AK-H & BK-H CAST IRON SHEAVES

- The AK-H and BK-H series of taper sheaves are designed for “H” style STL bushings
- Precision installation
- Easy assembly disassembly
- Manufactured in high quality grey cast iron
- Surface treatment: painting or black phosphating.
- Individually packaged
- “H” style bushings are available for bore sizes from 3/8” to 1-1/2”



STL Taper bushings • See page 16

STOCK “H” BUSHINGS • STL

Stock Bores	Keyseats	Stock Bores	Keyseats
3/8	None	1	1/4x1/16
7/16	None	1 1/16	1/4x1/16
1/2	1/8x1/16	1 1/8	1/4x1/16
9/16	1/8x1/16	1 3/16	1/4x1/16
5/8	3/16x3/32	1 1/4	1/4x1/16
11/16	3/16x3/32	1 5/16	5/16x1/16
3/4	3/16x3/32	1 3/8	5/16x1/16
13/16	3/16x3/32	1 3/8	3/8x1/16
7/8	3/16x3/32	1 7/16	3/8x1/16
15/16	1/4x1/8	1 1/2	3/8x1/16

MILLIMETER BORES • STL

Stock Bores	Keyseats	Stock Bores	Keyseats
10	None	24	8x3.5
11	None	25	8x3.5
12	None	28	8x3.5
14	5x2.5	30	8x3.5
16	5x2.5	32	10x4
18	6x3	35	10x4
19	6x3	36	10x4
20	6x3	38	10x4
22	6x3		

AK-H SHEAVES

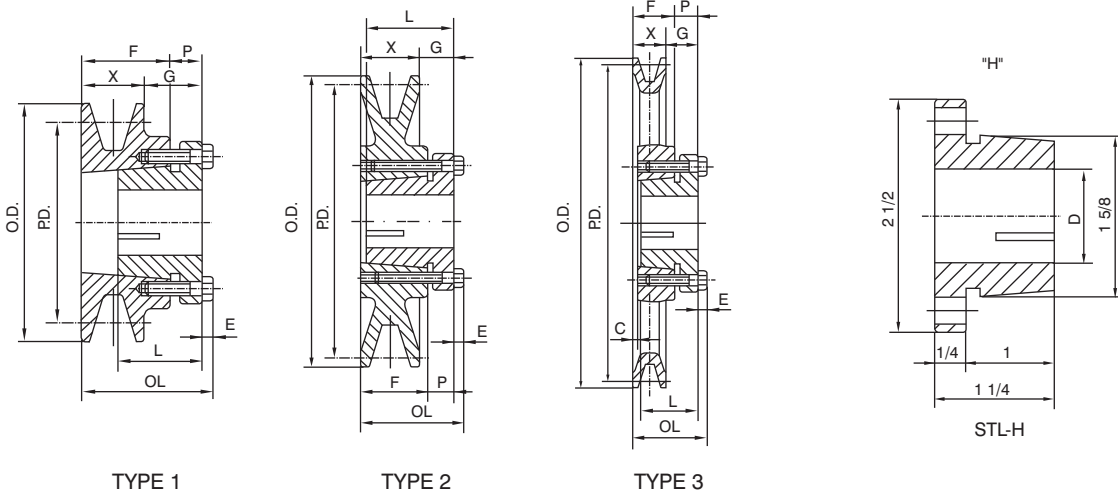

TYPE 1

TYPE 2

TYPE 3

STL-H

1 GROOVE • A or 3L-4L BELTS

Part Number	Diameter			Type	Dimensions								Wgt. Less Bush
	O.D.	P.D. A	P.D. 3L		OL	F	L	P	C	X	G	E	
AK30H	3.05	2.80	2.46	1	1 13/16	3/4	1 1/4	7/8	—	13/16	7/16	3/16	1.1
AK32H	3.25	3.00	2.66	1	1 13/16	3/4	1 1/4	7/8	—	13/16	7/16	3/16	1.2
AK34H	3.45	3.20	2.86	2	1 1/2	3/4	1 1/4	9/16	—	7/8	7/16	3/16	1.0
AK39H	3.75	3.50	3.16	2	1 1/2	3/4	1 1/4	9/16	—	7/8	7/16	3/16	1.4
AK41H	3.95	3.70	3.36	2	1 1/2	3/4	1 1/4	9/16	—	7/8	7/16	3/16	1.6
AK44H	4.25	4.00	3.66	2	1 1/2	3/4	1 1/4	9/16	—	7/8	7/16	3/16	1.9
AK46H	4.45	4.20	3.86	2	1 1/2	3/4	1 1/4	9/16	—	7/8	7/16	3/16	1.9
AK49H	4.75	4.50	4.16	2	1 1/2	3/4	1 1/4	9/16	—	7/8	7/16	3/16	2.1
AK51H	4.95	4.70	4.36	2	1 1/2	3/4	1 1/4	9/16	—	7/8	7/16	3/16	2.3
AK54H	5.25	6.00	4.66	2	1 1/2	3/4	1 1/4	9/16	—	7/8	7/16	3/16	2.0
AK56H	5.45	5.20	4.86	2	1 1/2	3/4	1 1/4	9/16	—	7/8	7/16	3/16	2.3
AK59H	5.75	5.50	5.16	2	1 1/2	3/4	1 1/4	9/16	—	7/8	7/16	3/16	2.4
AK61H	5.95	5.70	5.36	3	1 1/2	3/4	1 1/4	9/16	—	7/8	7/16	3/16	2.5
AK64H	6.25	5.00	5.66	3	1 1/2	3/4	1 1/4	9/16	—	7/8	7/16	3/16	2.7
AK66H	6.45	6.20	5.86	3	1 1/2	3/4	1 1/4	9/16	—	7/8	7/16	3/16	2.8
AK69H	6.75	6.50	6.16	3	1 1/2	3/4	1 1/4	9/16	—	7/8	7/16	3/16	3.2
AK71H	6.95	6.70	6.36	3	1 1/2	3/4	1 1/4	9/16	—	7/8	7/16	3/16	3.1
AK74H	7.25	7.00	6.66	3	1 1/2	3/4	1 1/4	9/16	—	7/8	7/16	3/16	3.3
AK79H	7.75	7.50	7.16	3	1 1/2	3/4	1 1/4	9/16	—	7/8	7/16	3/16	3.5
AK84H	8.25	8.00	7.66	3	1 1/2	3/4	1 1/4	9/16	—	7/8	7/16	3/16	3.6
AK89H	8.75	8.50	8.16	3	1 1/2	3/4	1 1/4	9/16	—	7/8	7/16	3/16	4.0
AK94H	9.25	9.00	8.66	3	1 1/2	3/4	1 1/4	9/16	—	7/8	7/16	3/16	4.4
AK99H	9.75	9.50	9.16	3	1 1/2	3/4	1 1/4	9/16	—	7/8	7/16	3/16	4.7
AK104H	10.25	10.00	9.66	3	1 1/2	3/4	1 1/4	9/16	—	7/8	7/16	3/16	4.5
AK109H	10.75	10.50	10.16	3	1 1/2	3/4	1 1/4	9/16	—	7/8	7/16	3/16	5.1
AK114H	11.25	11.00	10.66	3	1 1/2	3/4	1 1/4	9/16	—	7/8	7/16	3/16	5.5
AK124H	12.25	12.00	11.66	3	1 1/2	3/4	1 1/4	9/16	—	7/8	7/16	3/16	6.1
AK134H	13.25	13.00	12.66	3	1 1/2	3/4	1 1/4	9/16	—	7/8	7/16	3/16	7.4
AK144H	14.25	14.00	13.66	3	1 1/2	3/4	1 1/4	9/16	—	7/8	7/16	3/16	7.8
AK154H	15.25	15.00	14.66	3	1 1/2	3/4	1 1/4	9/16	—	7/8	7/16	3/16	8.8
AK184H	18.25	18.00	17.66	3	1 1/2	3/4	1 1/4	9/16	—	7/8	7/16	3/16	11.3

FOR STL TAPER BUSHING - SEE PAGE 16