

A/B-C-D • CAST IRON SHEAVES



LEESON offers a comprehensive line of A/B-C-D pulleys for "Quick Detachable" (QD) taper bushings.

Also referred to as classical V-Belt sheaves each item is made under ISO quality assurance systems.

Features:

GG25 high performance cast iron

Precision CNC machining

Precision balancing to 06.3

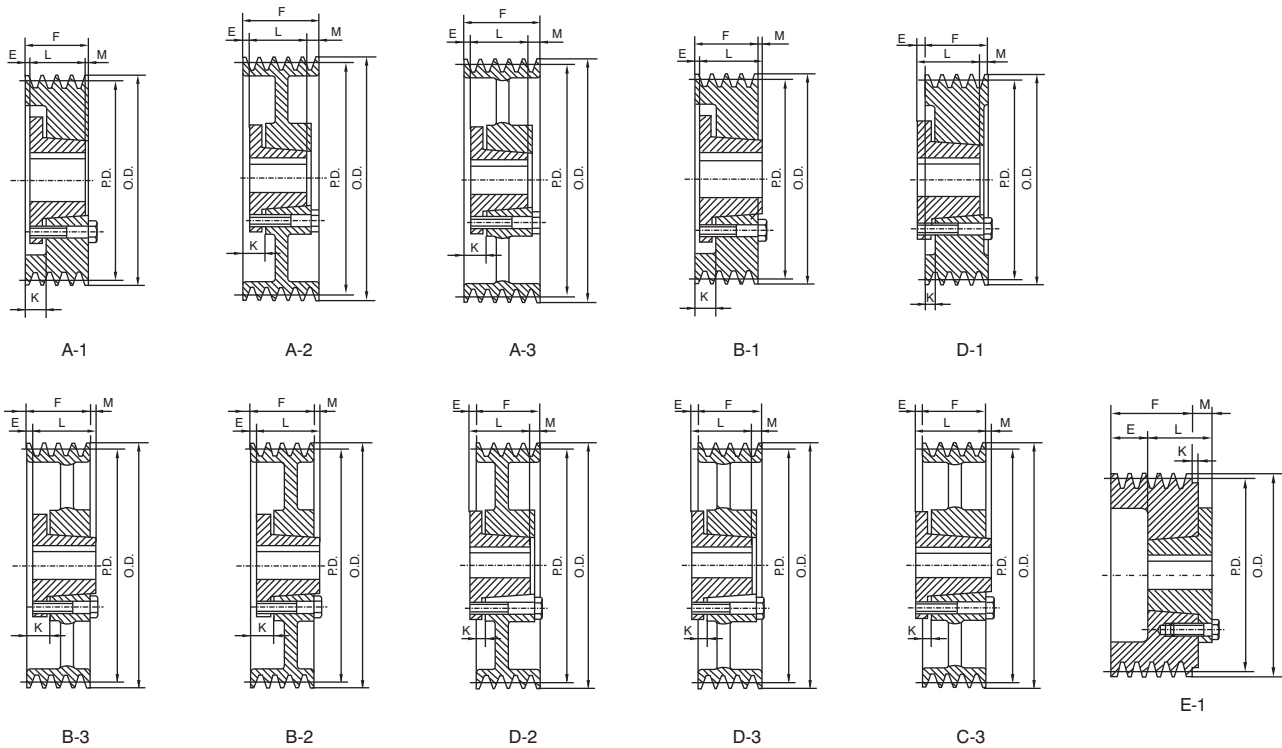

NOMENCLATURE FOR TAPER-LOCK SHEAVES FOR STANDARD NARROW V BELT

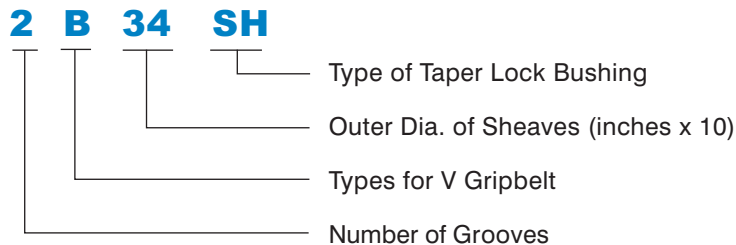

A/B-C-D

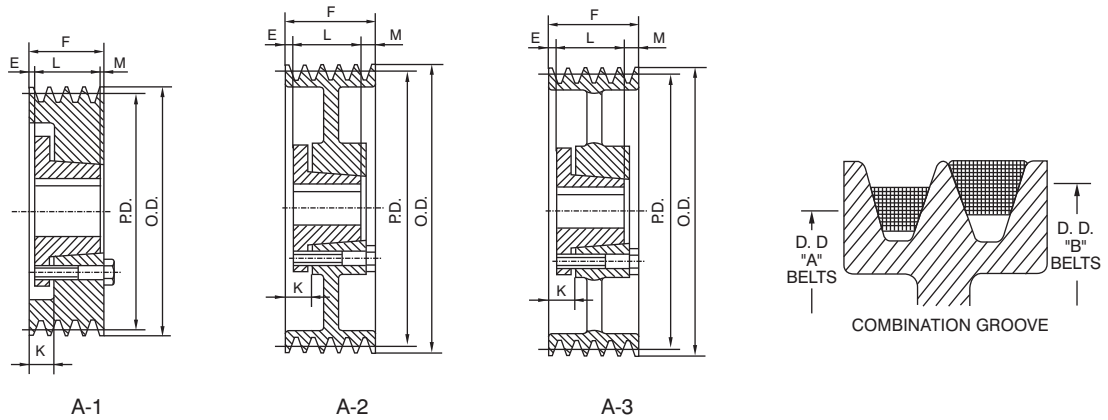

A/B-10

F = 7 3/4" (196.85mm)

Part No.	P.D.		O.D.	Bush	Type	Bush Max Bore	E	K	L	M	Wgt. Less Bush
	A Belt	B Belt									
10 B 54 SK	5.00	5.40	5.75	SK	A1	25/8	17/8	29/16	1 15/16	3 15/16	15
10 B 56 SK	5.20	5.60	5.95	SK	A1	25/8	17/8	29/16	1 15/16	3 15/16	18
10 B 58 SK	5.40	5.80	6.15	SK	A1	25/8	17/8	29/16	1 15/16	3 15/16	20
10 B 60 SF	5.60	6.00	6.35	SF	A1	2 15/16	17/8	29/16	2 1/16	3 13/16	22
10 B 62 SF	5.80	6.20	6.55	SF	A1	2 15/16	17/8	29/16	2 1/16	3 13/16	24
10 B 64 SF	6.00	6.40	6.75	SF	A1	2 15/16	17/8	29/16	2 1/16	3 13/16	25
10 B 66 SF	6.20	6.60	6.95	SF	A1	2 15/16	17/8	29/16	2 1/16	3 13/16	26
10 B 68 SF	6.40	6.80	7.15	SF	A1	2 15/16	17/8	29/16	2 1/16	3 13/16	27
10 B 70 SF	6.60	7.00	7.35	SF	A1	2 15/16	17/8	29/16	2 1/16	3 13/16	28
10 B 74 SF	7.00	7.40	7.75	SF	A1	2 15/16	17/8	29/16	2 1/16	3 13/16	31
10 B 80 SF	7.60	8.00	8.35	SF	A1	2 15/16	17/8	29/16	2 1/16	3 13/16	35
10 B 86 E	8.20	8.60	8.95	E	A1	3 1/2	2 1/4	3 1/8	2 5/8	2 7/8	38
10 B 94 E	9.00	9.40	9.75	E	A1	3 1/2	2 1/4	3 1/8	2 5/8	2 7/8	45
10 B 110 E	10.60	11.00	11.35	E	A2	3 1/2	2 1/4	3 1/8	2 5/8	2 7/8	59
10 B 124 E	12.00	12.40	12.75	E	A3	3 1/2	2 1/4	3 1/8	2 5/8	2 7/8	63
10 B 136 F	13.20	13.60	13.95	F	A3	3 15/16	1 1/16	2 1/16	3 5/8	3 1/16	78
10 B 154 F	15.00	15.40	15.75	F	A3	3 15/16	1 1/16	2 1/16	3 5/8	3 1/16	90
10 B 160 F	15.60	16.00	16.35	F	A3	3 15/16	1 1/16	2 1/16	3 5/8	3 1/16	96
10 B 184 F	18.00	18.40	18.75	F	A3	3 15/16	1 1/16	2 1/16	3 5/8	3 1/16	113
10 B 200 F	19.60	20.00	20.35	F	A3	3 15/16	1 1/16	2 1/16	3 5/8	3 1/16	124
10 B 250 F	24.60	25.00	25.35	F	A3	3 15/16	1 1/16	2 1/16	3 5/8	3 1/16	138
10 B 300 F	29.60	30.00	30.35	F	A3	3 15/16	1 1/16	2 1/16	3 5/8	3 1/16	200
10 B 380 J	37.60	38.00	38.35	J	A3	4 1/2	3/8	1 9/16	4 1/2	2 7/8	279

BORE RANGE FOR QTL BUSHING

Bush. Sym.	Min. Bore	Max. Bore with:		
		Full Keyway	Shallow Keyway	No Keyway
SK	1/2	2-1/8	2-1/2	25/8, 29/16
SF	1/2	2 1/4	2 7/8	2-15/16
E	7/8	2-7/8	3-1/2	—
F	1	3-1/4	3-15/16	4
J	1-1/2	3 13/16	4-1/2	—

STANDARD KEYWAY & KEY DIMENSION

Bores	Key Seat	Key
1/2-9/16	1/8x1/16	1/8x1/8
5/8-7/8	3/16x3/32	3/16x3/16
15/16-1 1/4	1/4x1/8	1/4x1/4
15/16-1 3/8	5/16x5/32	5/16x5/16
1 7/16-1 3/4	3/8x3/16	3/8x3/8
1 13/16-2 1/4	1/2x1/4	1/2x1/2
2 5/16-2 3/4	5/8x5/16	5/8x5/8
2 13/16-3 1/4	3/4x3/8	3/4x3/4
3 5/16-3 3/4	7/8x7/16	7/8x7/8
3 13/16-4 1/2	1x1/2	1x1

FOR QTL TAPER BUSHING - SEE PAGE 10

A/B-C-D