

# Product Data Sheet

## Vertical A.C. Motors Weather Protected Type I Holloshaft® High Thrust

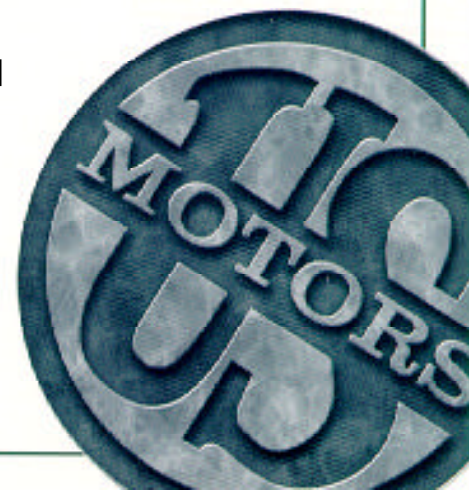

- For use on turbine, mix flow and propeller pumps
- 3 - 4000 Horsepower
- 3600 through 514 rpm
- Low and medium voltage through 6900 volts
- Three phase, 60 and 50 hertz
- Three efficiency levels - standard efficient, energy efficient and premium efficient



## Product Overview

Our Weather Protected Type I (WPI) Holloshaft® motors are constructed to minimize the entrance of rain, snow and airborne particles. Our enclosures exceed NEMA requirements because U.S. Motors has built in the extra protection needed for rugged outdoor applications. The ventilation system is designed to provide optimum cooling to the thrust bearing and electrical components and is available in all motor sizes.

These motors allow for easy pump impeller adjustment and maintain alignment of pump base to motor drive clutches. Steady bushings are available to give the mechanical characteristics of a solid shaft motor.

In our design concept, the high thrust vertical motor is arranged into four functional zones - the top zone is small and light to assure simplified access to the coupling area and inspection of the thrust bearing. Below this is the coupling area and the essential elements of thrust bearings with a large weather protected air intake to cool the motor and thrust bearing.

Next, the center, or winding section, develops the driving torque and includes the latest Insulife insulation systems. And below, the mounting base is compact and designed for momentary upthrust of the pump.

The benefit of the four zone design is a motor which is more easily installed and serviced and which allow operator protection and convenience.

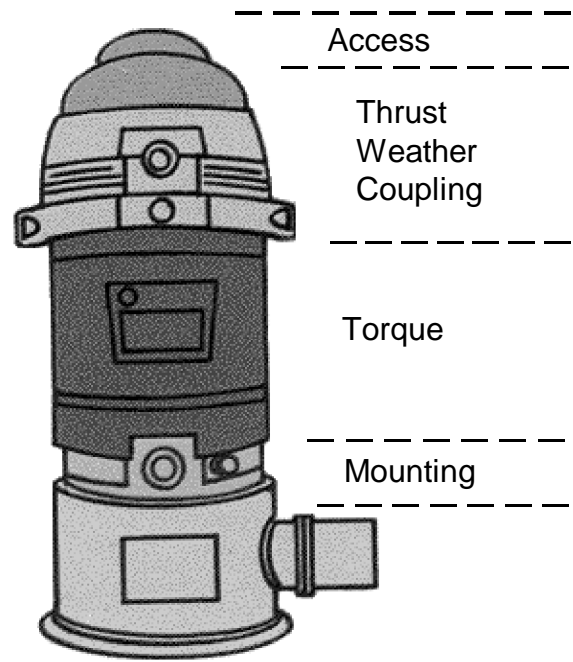

All open type vertical motors offered by U.S. Motors features a NEMA WPI enclosure as standard. It is designed to minimize the entrance of contaminants and airborne debris while protecting the internal components. Also, it is designed to prevent a 3/4 inch diameter rod from passing into the motor.

A unique feature of U.S. Motors' WPI design is the motor's air flow pattern. Cooling air is drawn in through the motor and exhausted in such a way to avoid drawing any pumped fluids into the motor should the pump's packing seal or mechanical seal fail. Furthermore, corrosion resistant screens and grills cover all openings preventing snakes, rodents, etc., from entering the motor. This is our standard product for outdoor service.

## Construction Features

Vertical motors with bearing configurations tailored to your specific needs is a hallmark of our product offering. U.S. Motors engineers can select from ball, angular contact, spherical roller and plate type bearing options to provide maximum bearing life regardless of the thrust conditions. U.S. Motors thrust bearing capacities are among the highest in the industry.

Our non-reverse ratchet, The Ball-O-Matic®, is without question the finest

ratchet available. The Ball-O-Matic prevents reverse rotation within 4.5 degrees of rotation, has unlimited depth setting and can be used in explosionproof applications.

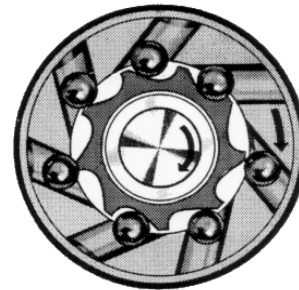

The Ball-O-Matic

The following diagram shows the typical Holloshaft® construction features:

1. **Lightweight Top Cover**
2. **Coupling** readily accessible
3. **Lockbar** holds shaft during adjustments
4. **Lifting Lugs** positioned for stability
5. **Protected Air Openings** exceed NEMA WPI requirements
6. **Precision Machined Mounting Base**, ample clearance for mounting bolt installation
7. **Rugged Bearing** withstands heavy load thrusts
8. **Large Plug** simplifies oil fills
9. **Sight Gauge Window** for quick oil level reading
10. **Metered Oil Flow** minimizes churning
11. **Dual Air Flow** system for uniform cooling of motor top and bottom
12. **Windings** Protected by new, synthetic materials
13. **Solid Die Cast Rotor** with integral fan blades

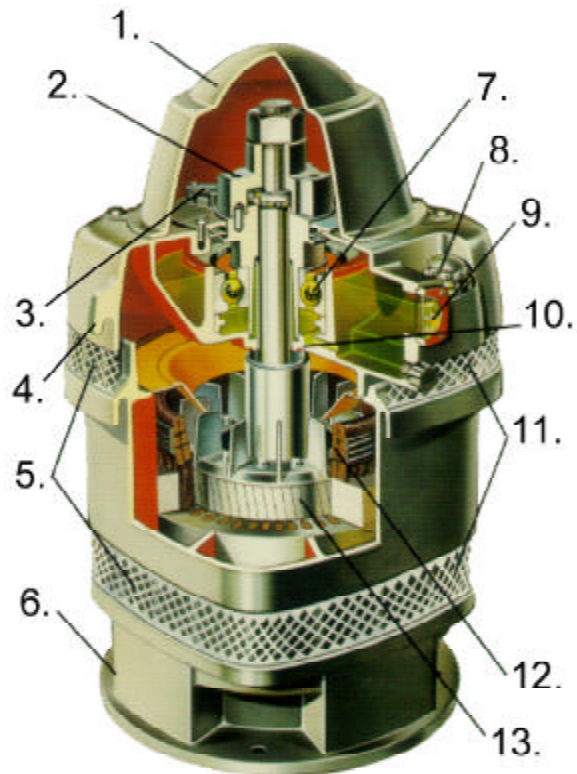

## Vertical Holloshaft WPI

All vertical products are supplied with the Insulife® winding system. For low voltage NEMA frame products, the copper wound stator core is insulated with non-hydroscopic Class F or H rated materials, and is then treated with polyester varnish for extra moisture protection. Vacuum pressure impregnation (VPI) is an available option on frames 320 and larger.

Medium voltage form wound motors are wound with Class F or Class H materials and are treated with two complete cycles of 100% solid epoxy VPI. This produces a minimum of 6 mils insulation build. U.S. Motors does not manufacture random wound medium voltage motors for quality reasons. Our Everseal® sealed winding system is an available option for form wound machines.

Another option available on our Vertical Motors is Inverter Grade® Insulation System. U.S. Motors was the first motor company to recognize that the pulse width modulation (PWM) adjustable frequency technology offered substantial payoff in better equipment control and increased energy savings, but it also created new challenges for existing motor insulation systems.

Our Inverter Duty product offers an Inverter Grade® insulation system with superior pulse endurance to withstand the waveform stresses produced by the PWM drives. In addition to the pulse resistant magnet wire, our protection system includes additional lacing on end turns, phase paper and additional dips and bakes. This system meets the stringent requirements outlined in NEMA MG-1, Part 31.

Many extra features, accessories and manufacturing steps have been incorporated into our vertical motor designs to improve the overall performance and greatly extend motor life. Available modifications include special altitude, special ambient temperatures, special balance and copper bar rotors. Available accessories include current transformers, space heaters, lightning arrestors and protective devices for bearings, windings and vibration.

Contact your U.S. Motors representative to learn more about our full compliment of accessories and modifications on our vertical motors to provide you with the exact product for your application.

**Stock, conversion or built-to-order, U.S. Motors has your vertical motor solution.**



**Emerson Motors**  
**8100 West Florissant Avenue, St. Louis, MO 63136**

*WWW Home Page: <http://www.usmotors.com>*



**REGIONAL OFFICES**  
DOMESTIC U.S. SALES  
INTERNATIONAL SALES  
MONTREAL, QUEBEC/CANADA  
TORONTO, ONTARIO/CANADA

**PHONE**  
(888) 637-7333  
(314) 553-3185  
(800) 361-5509  
(905) 475-4670

**FAX**  
(314) 553-1101  
(314) 553-2135  
(514) 332-5912  
(905) 475-4672

**REGIONAL OFFICES**  
MONTERREY, MEXICO  
CARACAS, VENEZUELA  
BOGOTA, COLOMBIA

**PHONE**  
(52) 8-389-1312  
(58) 02-2377522  
(57)1- 439-5420

**FAX**  
(52) 8-389-1310  
(58) 02-2329727  
(57)1- 439-5417