

PRODUCT INFORMATION PACKET

Model No: 056B17F5307
Catalog No: F105
1 1/2, 1725, TEFC, 56H-85, 1/60/115/208-230
Single Phase



Regal and Marathon are trademarks of Regal Beloit Corporation or one of its affiliated companies.
©2018 Regal Beloit Corporation, All Rights Reserved. MC017097E

Nameplate Specifications

Output HP	1.50 Hp	Output KW	1.1 kW
Frequency	60 Hz	Voltage	115/208-230 V
Current	15.2/8.2-7.6 A	Speed	1725 rpm
Service Factor	1.15	Phase	1
Efficiency	80 %	Duty	Continuous
Insulation Class	B	Design Code	L
KVA Code	J	Frame	56H
Enclosure	Totally Enclosed Fan Cooled	Overload Protector	Manual
Ambient Temperature	40 °C	Drive End Bearing Size	6203
Opp Drive End Bearing Size	6203	UL	Recognized (Not Protector)
CSA	Y	CE	N
IP Code	43		

Technical Specifications

Electrical Type	Capacitor Start Capacitor Run	Starting Method	Across The Line
Poles	4	Rotation	Selective Counterclockwise
Mounting	Rigid base	Motor Orientation	Horizontal
Drive End Bearing	Ball	Opp Drive End Bearing	Ball
Frame Material	Rolled Steel	Shaft Type	T
Overall Length	13.82 in	Frame Length	8.56 in
Shaft Diameter	0.625 in	Shaft Extension	2.312 in
Assembly/Box Mounting	F1 Only		
Outline Drawing	A-100138-856	Connection Diagram	A-102006-52

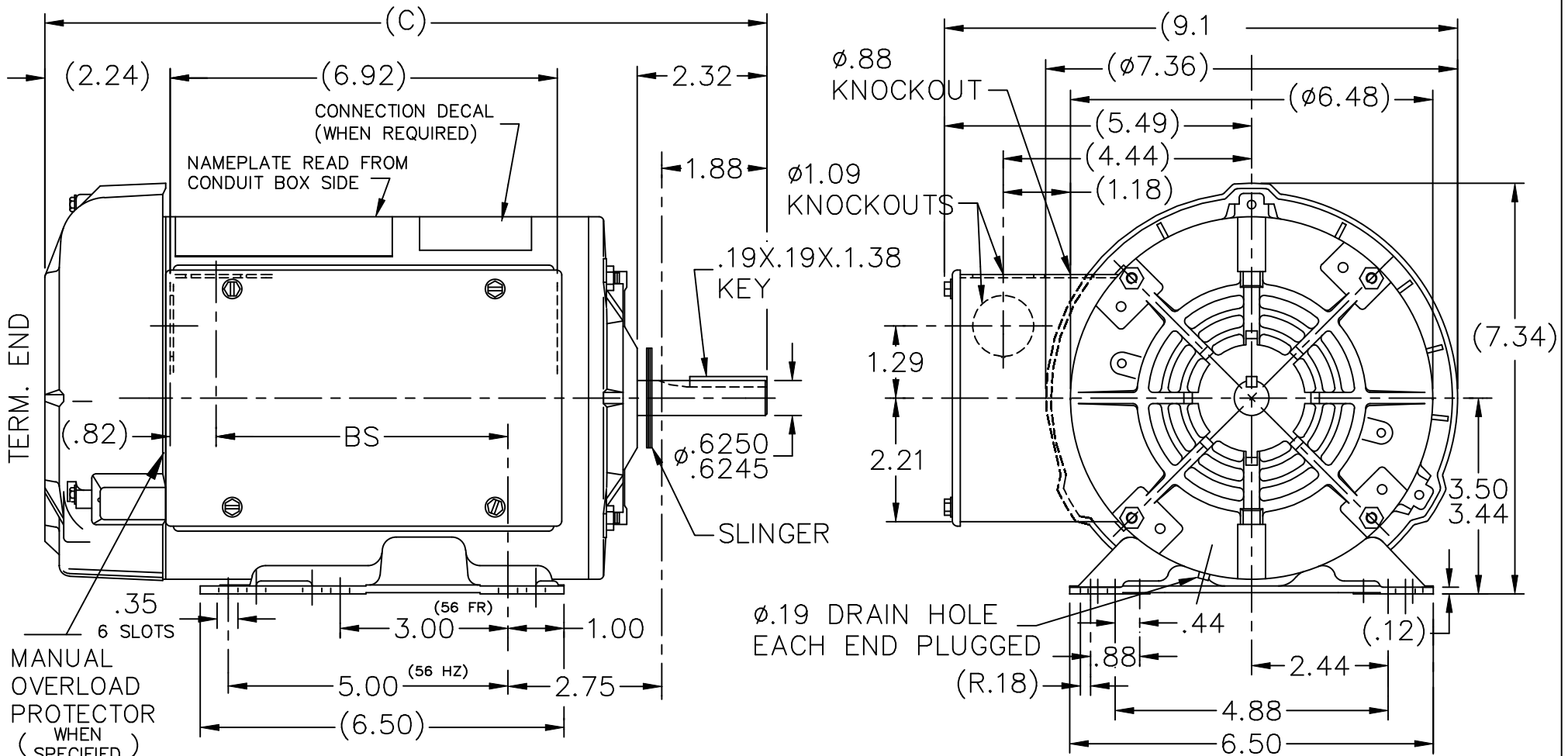

DASH	FR.	C	BS
856	56-85	13.82	6.14

				TOLERANCES UNLESS SPECIFIED			DRAWN ML 01-11-1992					
				DEC.	INCHES		CHK GK 01-12-1992					
				.X	±.1		APPD FG 01-12-1992					
				.XX	±.03	TITLE OUTLINE 56 FR.-BB-TEFC-1Ø-MAN. PROT.	SCALE 3=8					
4	REDRAWN IN AUTOCAD	TAT 06-13-2005	ML	.XXX	±.005		MAT'L. FINISH	REF				
3	REDRAWN ON CADD, ADDED CONN. DECAL	ML 01-12-1992		.XXXX	±.0005	FMF						
NO.	REVISION	BY & DATE	CHK	ANG	±7'30"	PREV						
THIS DRAWING IN DESIGN AND DETAIL IS OUR PROPERTY AND MUST NOT BE USED EXCEPT IN CONNECTION WITH OUR WORK ALL RIGHTS OF DESIGN AND INVENTION ARE RESERVED THIS IS AN ELECTRONICALLY GENERATED DOCUMENT - DO NOT SCALE THIS PRINT				RFP	CAD FILE 100138			SIZE	DRAWING NO.	PAGE	OF	REV.
				DIST	WP	A			100138			4

LOW VOLTAGE C.C.W.

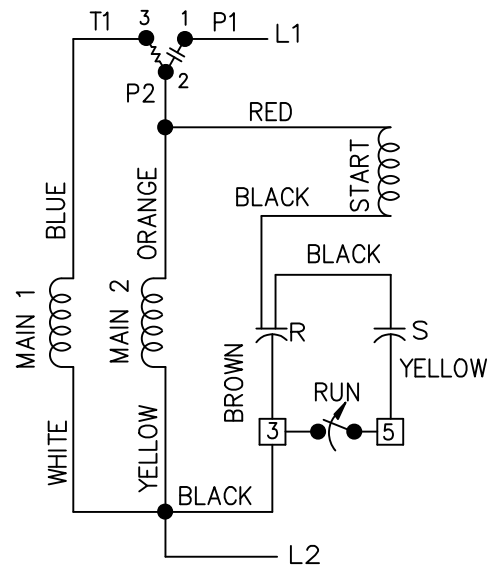

HIGH VOLTAGE C.C.W.

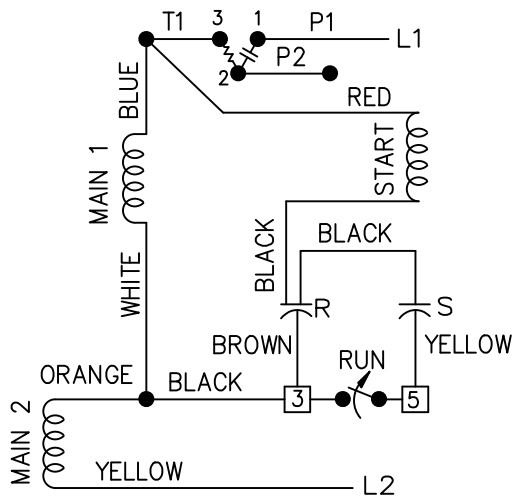

BROWN LEAD MAYBE CONNECTED ON POST 3 TO ELIMINATE GROUNDING

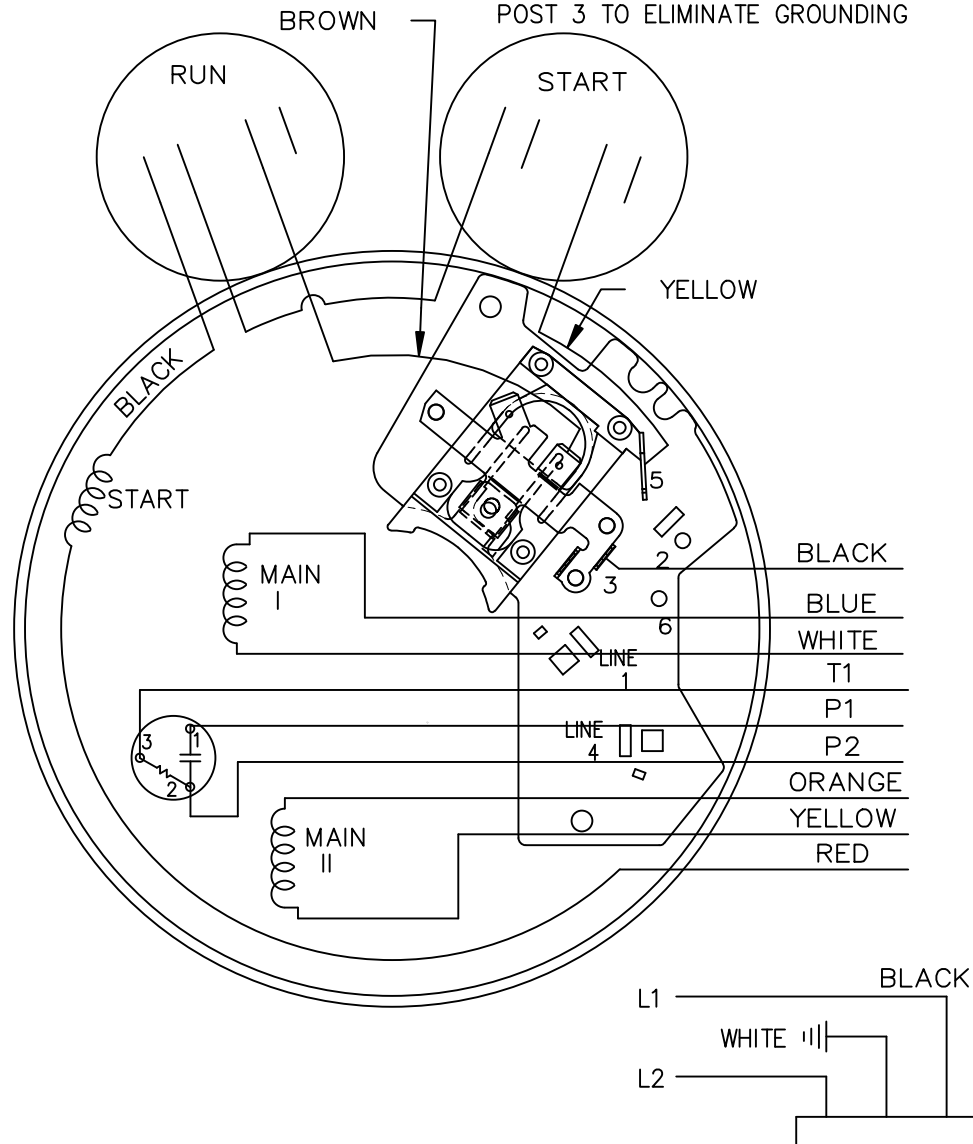

102006-52

DUAL VOLTAGE
CAP START-CAP RUN
OVERLOAD
SELECT ROTATION

LOW VOLT. CCW ROT.

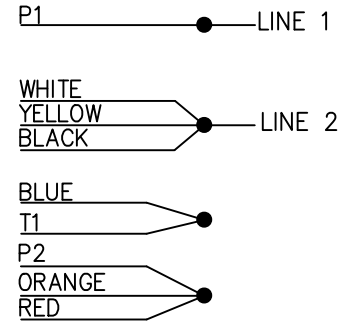

HIGH VOLT. CCW ROT.

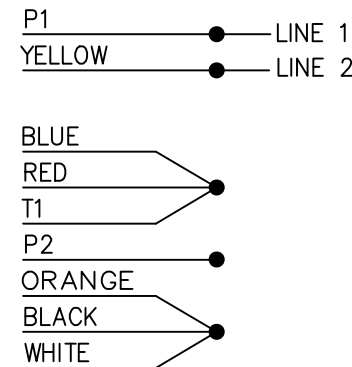

FOR CW ROT. EITHER
VOLTAGE INTERCHANGE
RED WITH BLACK LEAD.

13	CHG'ED SWITCH TO OPEN WHEN RUNNING ISAAC 11-2715	KBB 06-23-2011	EH	TOLERANCES UNLESS SPECIFIED	
12	REMOVE 1,2,3 & 4 ON LOW & HIGH VOLT CN 31436	TJB 02-14-2002	DRS	DEC.	INCHES
11	REMOVE BRAKE VIEW CN 31436	TJB 01-30-2002	DRS	.X	±.1
10	ADDED BROW LEAD DETAIL NOTE CN 24300-323	BJW 02-28-2000		.XX	±.02
9	ADDED CORD VIEW MU20434	BLR 07-01-1998		.XXX	±.005
8	CAP LEAD COLORS REVISED CN 16210	AJS 08-29-1994		.XXXX	±.0005
NO.	REVISION	BY & DATE	CHK	ANG	±7'30"

	DRAWN ML 05-09-1992	
	CHK GK 05-09-1992	APPD FG 05-19-1992
TITLE CONNECTION DIAGRAM		SCALE 5=8
MAT'L.		REF
FINISH		FMF
		PREV

THIS DRAWING IN DESIGN AND DETAIL IS OUR PROPERTY AND MUST NOT BE USED EXCEPT IN CONNECTION WITH OUR WORK ALL RIGHTS OF DESIGN AND INVENTION ARE RESERVED THIS IS AN ELECTRONICALLY GENERATED DOCUMENT - DO NOT SCALE THIS PRINT

RFP	CAD FILE 102006-52	SIZE A	DRAWING NO. 102006-52	PAGE OF	REV. 13
DIST WP					

