

PRODUCT INFORMATION PACKET

Model No: 184TTFCD6076
Catalog No: GT1008A
2,1200,TEFC,184T,3/60/230/460
Totally Enclosed Fan Cooled (TEFC)



Regal and Marathon are trademarks of Regal Beloit Corporation or one of its affiliated companies.
©2018 Regal Beloit Corporation, All Rights Reserved. MC017097E



Nameplate Specifications

Output HP	2 Hp	Output KW	1.5 kW
Frequency	60 Hz	Voltage	230/460 V
Current	6.0/3.0 A	Speed	1173 rpm
Service Factor	1.15	Phase	3
Efficiency	88.5 %	Duty	Continuous
Insulation Class	7	Design Code	B
KVA Code	K	Frame	184T
Enclosure	Totally Enclosed Fan Cooled	Overload Protector	No
Ambient Temperature	40 °C	Drive End Bearing Size	6206
Opp Drive End Bearing Size	6205	UL	Listed
CSA	Y	CE	Y
IP Code	55		

Technical Specifications

Electrical Type	Squirrel Cage Inverter Rated	Starting Method	Line Or Inverter
Poles	6	Rotation	Reversible
Mounting	Rigid base	Motor Orientation	Horizontal
Drive End Bearing	Ball	Opp Drive End Bearing	Ball
Frame Material	Cast Iron	Shaft Type	T
Frame Length	6.85 in	Shaft Diameter	1.125 in
Shaft Extension	2.75 in	Assembly/Box Mounting	F1/F2 Capable
Outline Drawing	SS620855-184	Connection Diagram	EE7308

This is an uncontrolled document once printed or downloaded and is subject to change without notice. Date Created: 07/02/2018

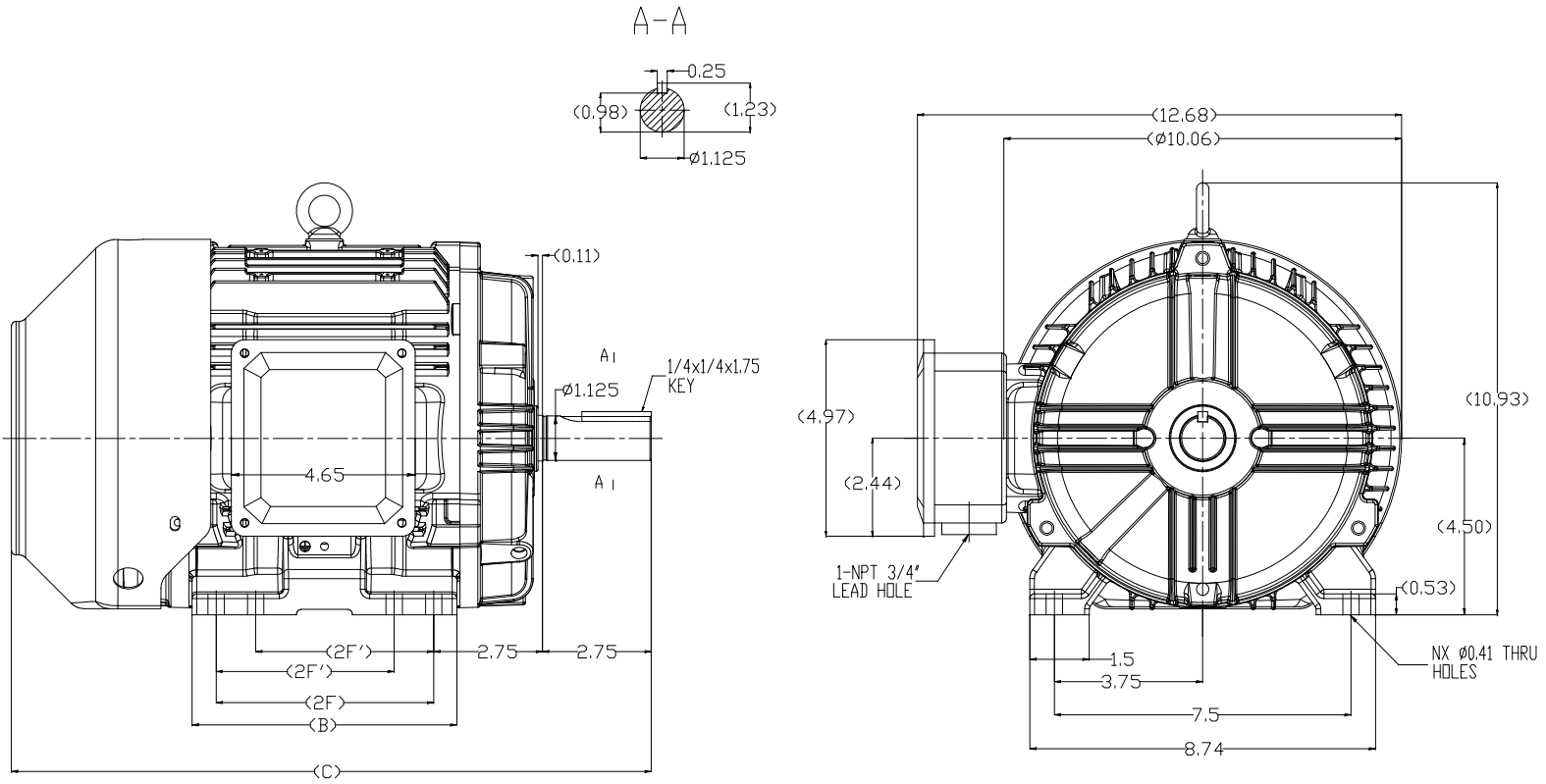

182T	15.08	5.67	4.50	/	4
184T	16.08	6.69	5.50	4.50	8
FRAME	C	B	2F	2F'	N

		TOLERANCES UNLESS SPECIFIED		REGAL-BELOIT CORPORATION		DRAWN WZ 8-11-2017	
		DEC.	INCHES			CHK WY 8-11-2017	
		.X	±.1	TITLE		SCALE 1=1	
		.XX	±.03	182/184T FR TEFC-CAST IRDN		REF	
		.XXX	±.005	MAT'L.		FMF WUXI	
A	RELEASED FOR PRODUCTION	ECC-0141896	BW 3/22/2018	CD	XXXX	±.0005	FINISH
NO.	REVISION	BY & DATE	CHK	ANG	±1/2"	CAD FILE SS620855	
THIS DRAWING IN DESIGN AND DETAIL IS OUR PROPERTY AND MUST NOT BE USED EXCEPT IN CONNECTION WITH OUR WORK ALL RIGHTS OF DESIGN AND INVENTION ARE RESERVED THIS IS AN ELECTRONICALLY GENERATED DOCUMENT - DO NOT SCALE THIS PRINT				RFP	DRAWING NO.		REV.
				DIST	SIZE B	SS620855	A

EE7308

THREE PHASE
DUAL VOLTAGE MOTOR



VIEW OF TERMINAL END

REF.
WINDING DIAGRAM

T8Y, T2Y, T2BL, T4BX, T2EC, T2G
T6BZ, T2B, T6BL, T4AV, T6B, T4B

OPTIONAL CORD
CONNECTION

L1 — WHITE
L2 — RED
L3 — BLACK

NO.	REVISION	BY & DATE	CHK	ANG	TOLERANCES UNLESS SPECIFIED		FINISH	DRAWN RM 11/20/1990				
					DEC.	INCHES						
5	CHG TO REGAL LOGO	SL 09/10/2015	AB					CHK ML 11/21/1990				
4	REVISED IEC NOTATIONS	MSG 11/15/2011	CMN	.X	±.1			APPD SAS 04/24/2003				
3	ADDED IEC NOTATIONS... (U1), (V1) ETC. MU95194	MSG 5/10/2010	MJS	.XX	±.02			SCALE 1=1				
2	ADDED THE OPTIONAL CORD CONNECTION MU46318	RDH 04/24/2003	DRS	.XXX	±.005		TITLE CONNECTION DIAGRAM 3Ø - DUAL VOLTAGE MOTOR	REF				
1	REDRAWN	RM 11/20/1990		.XXXX	±.0005		MAT'L.	FMF				
					±7'30"			PREV				
THIS DRAWING IN DESIGN AND DETAIL IS OUR PROPERTY AND MUST NOT BE USED EXCEPT IN CONNECTION WITH OUR WORK ALL RIGHTS OF DESIGN AND INVENTION ARE RESERVED THIS IS AN ELECTRONICALLY GENERATED DOCUMENT - DO NOT SCALE THIS PRINT							RFP	CAD FILE ee7308	SIZE A	DRAWING NO. EE7308	PAGE OF 5	REV. 5
							DIST WP					



Regal Beloit America, Inc.



**P.O. BOX 8003
WAUSAU, WI 54401-8003
PH. 715-675-3311**

CERTIFICATION DATA SHEET

CUSTOMER: CUSTOMER PO #:
ORDER #: MODEL #: 184TTFCDD6076 AA
CONN. DIAGRAM: EE7308 CUSTOMER PART #:
OUTLINE: SS620855-184 MOUNTING: F1/F2 CAPABLE
WINDING #: HE31126009 3

TYPICAL MOTOR PERFORMANCE DATA

HP	KW	SYNC. RPM	F.L. RPM	FRAME	ENCLOSURE	KVA CODE	DESIGN	
2&1 1/2	1.49&1.12	1200	1173&977	184T	TEFC	K	B	
PH	Hz	VOLTS	AMPS	START TYPE	DUTY	INSL	S.F.	AMB° C
3	60/50	230/460&190/380	6/3&6.2/3.1	LINE OR INVERTER	CONTINUOUS	7	1.15/1.15	40

FULL LOAD EFF:	88.5&81	3/4 LOAD EFF:	87.5	1/2 LOAD EFF:	85.5	GTD. EFF	87.5	ELEC. TYPE
FULL LOAD PF:	70&67	3/4 LOAD PF:	63	1/2 LOAD PF:	51	SQ CAGE INV RATED		
F.L. TORQUE	LOCKED ROTOR AMPS	L.R. TORQUE	B.D. TORQUE	F.L. RISE° C				
9 LB-FT	47 / 23.5	23.5 LB-FT	260 %	31 LB-FT	350 %	60		

SOUND PRESSURE @ 3 FT.	SOUND POWER	ROTOR WK^2	MAX. WK^2	SAFE STALL TIME	STARTS / HOUR	APPROX. MOTOR WGT
50 DBA	60 DBA	- LB-FT^2	- LB-FT^2	15 SEC.	2	- LBS.

***** SUPPLEMENTAL INFORMATION *****

DE BRACKET TYPE	ODE BRACKET TYPE	MOUNT TYPE	ORIENTATION	SEVERE DUTY	HAZARDOUS LOCATION	DRIP COVER	SCREENS	PAINT
STANDARD	STANDARD	RIGID	HORIZONTAL	FALSE	DIVISION 2 T2B	FALSE	NONE	BLUE (ENAMEL)
BEARINGS		GREASE	SHAFT TYPE	SPECIAL DE	SPECIAL ODE	SHAFT MATERIAL	FRAME MATERIAL	
DE ODE	BALL BALL	POLYREX EM	T	NONE	NONE	1045 HOT ROLLED (C-204)	CAST IRON	

THERMO-PROTECTORS				THERMISTORS			SPACE HEATERS	
THERMOSTATS	PROTECTORS	WDG RTDS	BRG RTDS	NONE	FALSE	NONE	NONE	VOLTS
NONE	NOT	NONE	NONE					

INVERTER	TORQUE: CONSTANT 20:1/VARIABLE 20:1
INV. HP SPEED RANGE:	NONE
ENCODER:	NONE
O	NONE
T	NONE
E	PPR
S	NONE
BRAKE:	NONE
	P/N NONE
	NONE
	FT-LB NONE
	V NONE
	Hz

PREPARED BY: Anusha Muthyala
DATE: 05/04/2018 02:32:21 AM
FORM 3531 REV.3 02/07/99
 ** Subject to change without notice.

MARATHON ELECTRIC CORPORATION

TYPICAL PERFORMANCE CURVE for AC MOTOR

Customer

Curve at

460

Volts

HP 2&1.5

PHASE 3

Model No 184TTFC6076

60

HZ

VOLTS 230/460&190/380

2

HP

HZ 60&50

RPM 1173&977

Catalog No GT1008A

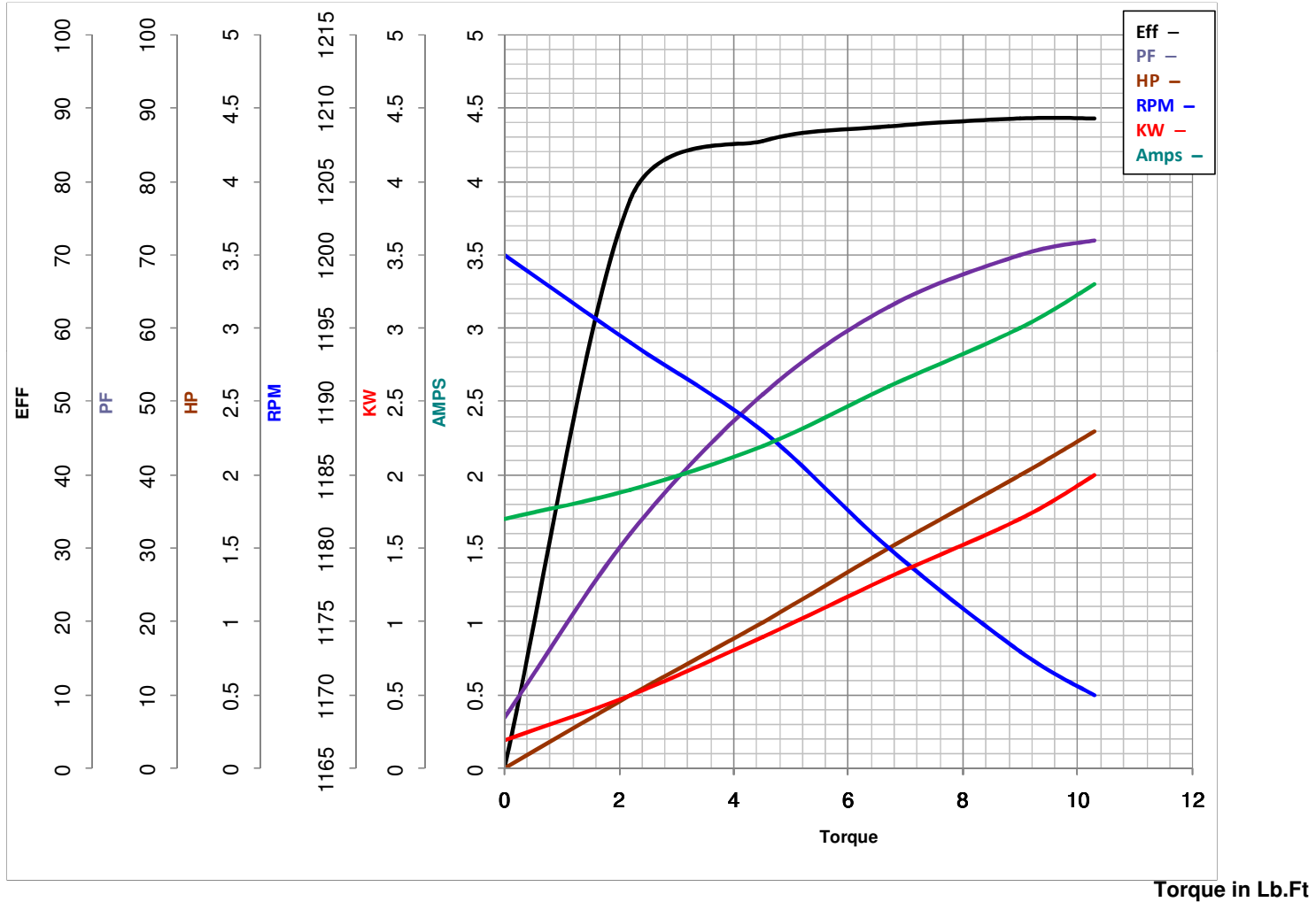

FL TORQUE	<u>9</u>	Lb.Ft	FL AMPS	<u>6/3</u>	
BD TORQUE	<u>31.0</u>	Lb.Ft	PU TORQUE	<u>18.0</u>	Lb.Ft
LR TORQUE	<u>23.5</u>	Lb.Ft	LR AMPS	<u>23.5</u>	
WINDING	HE31126009-3	Prepared By	ANUSHA M	Date	5/4/2018