

# 115VAC Linear Actuators

Dayton®

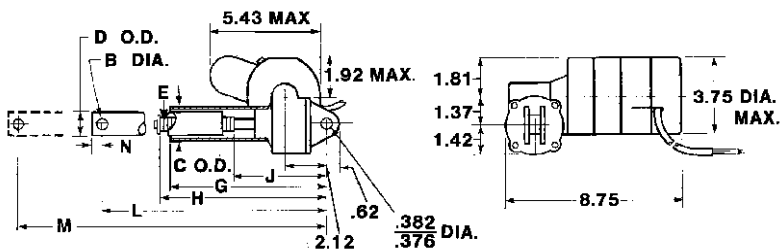

No. 1XFY1



TENV



No. 1AFX8

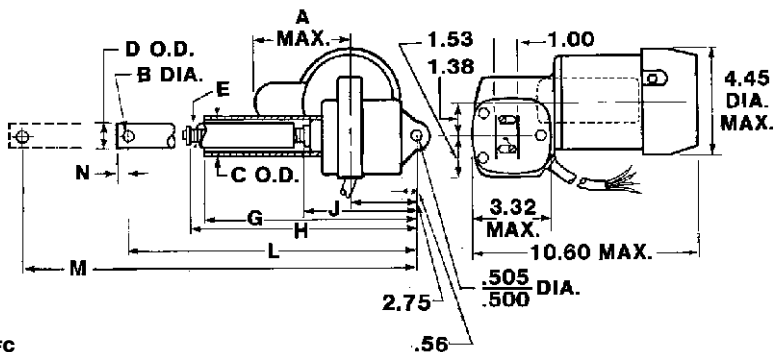

TEFC

Rated Load (Lbs.)	Enclosure	Travel (In.)	Speed (In./Min.)	Duty Cycle %†	Cont. Duty Cont. Travel (In.*)	Full-Load Amps at 115 VAC	Item No.	Shpg. Wt.
300	Totally Enclosed Nonventilated	12	19.4	25	194	1.4	1XFY1	27.8
400	Totally Enclosed Nonventilated	12	8.4	25	84	1.4	1XFY9	27.8
1000	Totally Enclosed Fan-Cooled	12	8.9	25	89	1.8	1AFX8	10.2
1000	Totally Enclosed Fan-Cooled	12	20	25	140	4.2	1AFX7	10.2
1300	Totally Enclosed Fan-Cooled	10	8.9	25	62	4.2	1AFX6	10.2

(\*) Total inches of travel (up and down) until thermal overload protector cuts out. Protector automatically resets after cool-down period. (†) Duty cycle is based on 1 minute on/3 minutes off.

Item No.	Dimensions (In.)										
	A	B	C	D	E	G	H	J	L	M	N
1XFY1	—	0.382/0.376	1.66	1.38	3/4-8	18.92	18.63	4.63	20.0	32.0	0.5
1XFY9	—	0.382/0.376	1.66	1.38	3/4-8	18.92	18.63	4.63	20.0	32.0	0.5
1AFX8	3.94	0.382/0.376	1.66	1.38	3/4-5	18.94	19.35	4.47	20.5	32.5	0.5
1AFX7	3.94	0.382/0.376	1.66	1.38	3/4-5	18.94	19.35	4.47	20.5	32.5	0.5
1AFX6	3.94	0.505/0.500	2.50	2.00	1-5	19.00	19.20	5.30	20.5	30.5	0.75