



100 & 175 Series Parallel Shaft AC

UP TO 170 IN-LBS CONTINUOUS

The 100 and 175 Series offer a wide speed range and many voltage options in an ultra-compact package.

AC PARALLEL SHAFT GEARMOTORS

Specifications

Gearhead	Motor	Features
Gearing: 100 Series: 1st-stage helical steel, balance powdered metal or steel 175 Series: 1st-stage helical steel, balance heat treated steel or powdered metal Housing: Precision machined die cast aluminum Lubrication: Lifetime oil bath, sealed and gasketed Bearings: Needle output Shafts: Hardened steel Mounting: Face or optional footplate (any angle)	Motor Type: Permanent split capacitor and 3 phase Rotation: Reversible Insulation: Class B minimum Finish: Gloss black powder coat 175 3-phase unpainted Enclosure: Open 1/80 & 1/10 HP TENV 1/20 HP TEFC 1/12 HP	<ul style="list-style-type: none"> Included junction box Included capacitor on PSC units Rear shaft on PSC units 175-3 Phase IP 54 enclosure

Optional Features

- Power-off brake for PSC motors
 - Footplate kit
- Part number: P125-100-9998

Additional Information

Current drawings and stock status available at www.bisongear.com

Wiring diagram pages 88-91

See pages 86-87 for additional accessories

ISIS - Products available off-shelf

SNS - Min. order quantity and lead time

100 Series PSC 115V

Part Number	Speed (RPM)**	Torque (in-lbs)	Input HP	Gear Ratio	Stages	OHL*	Amps	Hz	Shipping Wt.
016-102-1369	1.2	100**	1/80	1369.3	5	115	.30/.32	60/50	6.5
016-102-0702	2.3	100**	1/80	702.1	5	115	.30/.32	60/50	6.5
016-102-0362	4.5	100**	1/80	361.7	4	115	.30/.32	60/50	6.5
016-102-0186	8.8	76	1/80	185.5	4	85	.30/.32	60/50	6.5
016-101-0100	17	100**	1/20	95.5	3	150	.60	60	7.5
016-101-0072	22	100**	1/20	71.7	3	150	.60	60	7.5
016-101-0050	33	96	1/20	49.0	3	130	.60	60	7.5
016-101-0037	43	62	1/20	36.7	3	160	.60	60	7.5
016-101-0026	63	49	1/20	25.2	2	230	.60	60	7.5
016-101-0017	95	30	1/20	16.8	2	225	.60	60	7.5
016-101-0013	124	25	1/20	12.9	2	220	.60	60	7.5
016-101-0010	154	20	1/20	10.5	2	218	.60	60	7.5
016-101-0007	240	13	1/20	6.7	1	200	.60	60	7.5
016-101-0005	320	10	1/20	5.0	1	200	.60	60	7.5

107 Series 3-Phase Inverter Duty 230V

For more specifications see page 62

175 Series PSC 115V and 115/230V

Part Number	Speed (RPM)**	Torque (in-lbs)	Input HP	Gear Ratio	Stages	OHL*	Volts AC	Amps	Hz	Shipping Wt.
016-175-1369	1.3	160**	1/20	1369.3	5	115	115/230	.32/.18	60/50	8.25
016-175-0702	2.5	130**	1/20	702.1	5	115	115/230	.33/.19	60/50	8.25
016-175-0362	4.5	155**	1/20	361.7	4	115	115/230	.38/.21	60/50	8.25
016-175-0186	8.8	170**	1/20	185.5	4	85	115/230	.46/.26	60/50	8.25
016-175-0096	17	150**	1/20	95.5	3	150	115/230	.56/.29	60/50	8.25
016-175-0049	33	165	1/10	49.1	3	130	115	1.05	60	10
016-175-0025	63	90	1/10	25.2	2	230	115	1.05	60	10
016-175-0013	124	47	1/10	12.9	2	220	115	1.05	60	10
016-175-0007	240	25	1/10	6.7	1	200	115	1.05	60	10

175 Series 3-Phase 230/460V

Part Number	Speed (RPM)**	Torque (in-lbs)	Input HP	Gear Ratio	Stages	OHL*	Amps	Hz	Shipping Wt.
017-175-0096	17	150**	1/12	95.5	3	150	.60/.35	60/50	9
017-175-0050	32	138	1/12	49.0	3	130	.60/.35	60/50	9
017-175-0025	63	74	1/12	25.2	2	230	.60/.35	60/50	9
017-175-0013	122	38	1/12	12.9	2	220	.60/.35	60/50	9

* Maximum overhung load on center of output shaft. ** Output torque is gear limited.

*** All speeds given are at 60 HZ. For dual frequency units, speed will be 5/6 of rated speed.

100 & 175 Series Parallel Shaft AC

100 & 175 AC

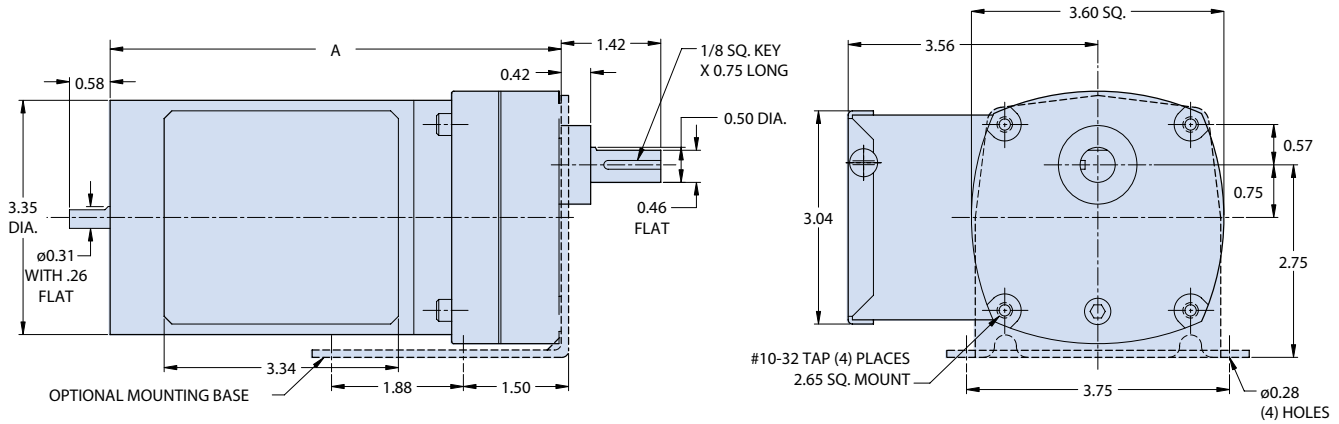

100 PSC 115V

HP	Stages	A
1/20	1, 2, 3	6.44
1/80	4, 5	6.26

175 PSC 115V and 115/230V

HP	Stages	A
1/10	1, 2, 3	7.40
1/20	3	6.78
1/20	4, 5	7.48

175 3-Phase

