



### AK-H & BK-H CAST IRON SHEAVES

- The AK-H and BK-H series of taper sheaves are designed for “H” style STL bushings
- Precision installation
- Easy assembly disassembly
- Manufactured in high quality grey cast iron
- Surface treatment: painting or black phosphating.
- Individually packaged
- “H” style bushings are available for bore sizes from 3/8" to 1-1/2"



STL Taper bushings • See page 16

### STOCK “H” BUSHINGS • STL

Stock Bores	Keyseats	Stock Bores	Keyseats
3/8	None	1	1/4x1/16
7/16	None	1 1/16	1/4x1/16
1/2	1/8x1/16	1 1/8	1/4x1/16
9/16	1/8x1/16	1 3/16	1/4x1/16
5/8	3/16x3/32	1 1/4	1/4x1/16
11/16	3/16x3/32	1 5/16	5/16x1/16
3/4	3/16x3/32	1 3/8	5/16x1/16
13/16	3/16x3/32	1 3/8	3/8x1/16
7/8	3/16x3/32	1 7/16	3/8x1/16
15/16	1/4x1/8	1 1/2	3/8x1/16

### MILLIMETER BORES • STL

Stock Bores	Keyseats	Stock Bores	Keyseats
10	None	24	8x3.5
11	None	25	8x3.5
12	None	28	8x3.5
14	5x2.5	30	8x3.5
16	5x2.5	32	10x4
18	6x3	35	10x4
19	6x3	36	10x4
20	6x3	38	10x4
22	6x3		

**2AK-H SHEAVES**

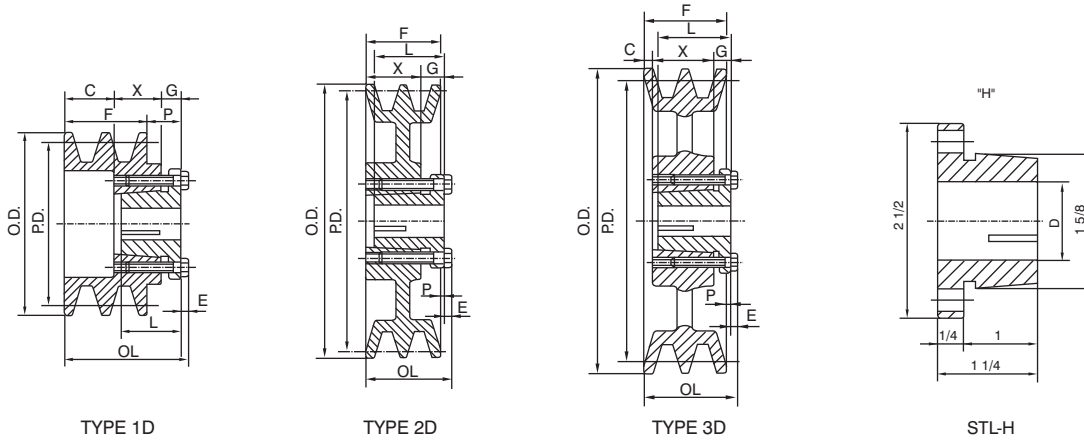

**2 GROOVE • A or 3L-4L BELTS**

Part Number	Diameter			Type	Dimensions								Wgt. Less Bush
	O.D.	P.D. A	P.D. 3L		OL	F	L	P	C	X	G	E	
2AK30H	3.05	2.80	2.46	1D	27/16	13/8	1 1/4	7/8	15/16	7/8	7/16	3/16	1.4
2AK32H	3.25	3.00	2.66	1D	27/16	13/8	1 1/4	7/8	15/16	7/8	7/16	3/16	1.7
2AK34H	3.45	3.20	2.86	1D	2	13/8	1 1/4	7/16	1/2	7/8	7/16	3/16	1.8
2AK39H	3.75	3.50	3.16	1D	2	13/8	1 1/4	7/16	1/2	7/8	7/16	3/16	1.8
2AK41H	3.95	3.70	3.36	2D	1 1/2	13/8	1 1/4	1/16	—	7/8	7/16	3/16	1.9
2AK44H	4.25	4.00	3.66	2D	1 1/2	13/8	1 1/4	1/16	—	7/8	7/16	3/16	2.4
2AK46H	4.45	4.20	3.86	2D	1 1/2	13/8	1 1/4	1/16	—	7/8	7/16	3/16	2.5
2AK49H	4.75	4.50	4.16	2D	1 1/2	13/8	1 1/4	1/16	—	7/8	7/16	3/16	3.1
2AK51H	4.95	4.70	4.36	2D	1 1/2	13/8	1 1/4	1/16	—	7/8	7/16	3/16	3.2
2AK54H	5.25	5.00	4.66	2D	1 1/2	13/8	1 1/4	1/16	—	7/8	7/16	3/16	3.4
2AK56H	5.45	5.20	4.86	2D	1 1/2	13/8	1 1/4	1/16	—	7/8	7/16	3/16	3.6
2AK59H	5.75	5.50	5.16	3D	1 1/2	13/8	1 1/4	1/16	—	7/8	7/16	3/16	3.4
2AK61H	5.95	5.70	5.36	3D	1 1/2	13/8	1 1/4	1/16	—	7/8	7/16	3/16	3.3
2AK64H	6.25	6.00	5.66	3D	1 1/2	13/8	1 1/4	1/16	—	7/8	7/16	3/16	3.9
2AK74H	7.25	7.00	6.66	3D	1 1/2	13/8	1 1/4	1/16	—	7/8	7/16	3/16	4.9
2AK84H	8.25	8.00	7.66	3D	1 1/2	13/8	1 1/4	1/16	—	7/8	7/16	3/16	5.8
2AK94H	9.25	9.00	8.66	3D	1 1/2	13/8	1 1/4	1/16	—	7/8	7/16	3/16	6.1
2AK104H	10.25	10.00	9.66	3D	1 1/2	13/8	1 1/4	1/16	—	7/8	7/16	3/16	7.7
2AK114H	11.25	11.00	10.66	3D	1 1/2	13/8	1 1/4	1/16	—	7/8	7/16	3/16	8.5
2AK124H	12.25	12.00	11.66	3D	1 1/2	13/8	1 1/4	1/16	—	7/8	7/16	3/16	9.5
2AK134H	13.25	13.00	12.66	3D	1 1/2	13/8	1 1/4	1/16	—	7/8	7/16	3/16	11.4
2AK144H	14.25	14.00	13.66	3D	1 1/2	13/8	1 1/4	1/16	—	7/8	7/16	3/16	11.9
2AK154H	15.25	15.00	14.66	3D	1 1/2	13/8	1 1/4	1/16	—	7/8	7/16	3/16	13.3
2AK184H	18.25	18.00	17.66	3D	1 1/2	13/8	1 1/4	1/16	—	7/8	7/16	3/16	16.8

FOR STL TAPER BUSHING - SEE PAGE 16

V PULLEYS