

A/B-C-D • CAST IRON SHEAVES



LEESON offers a comprehensive line of A/B-C-D pulleys for "Quick Detachable" (QD) taper bushings.

Also referred to as classical V-Belt sheaves each item is made under ISO quality assurance systems.

Features:

GG25 high performance cast iron

Precision CNC machining

Precision balancing to 06.3

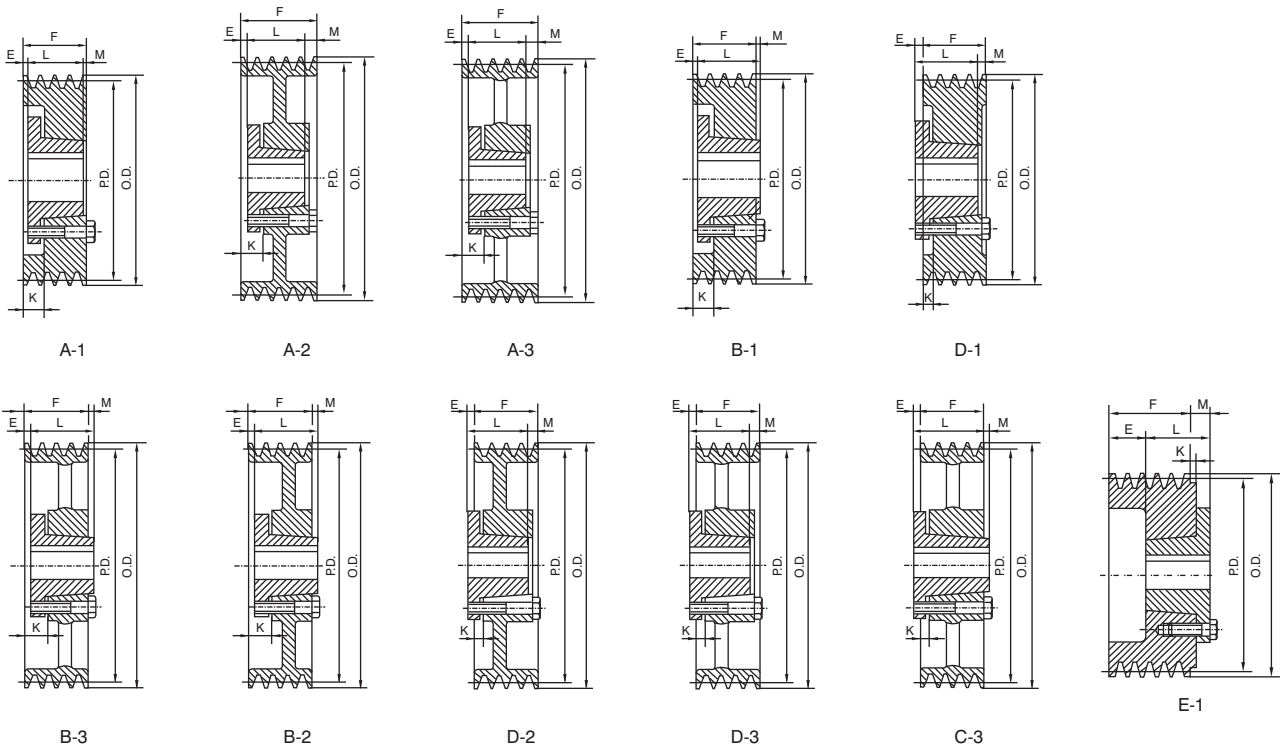

NOMENCLATURE FOR TAPER-LOCK SHEAVES FOR STANDARD NARROW V BELT

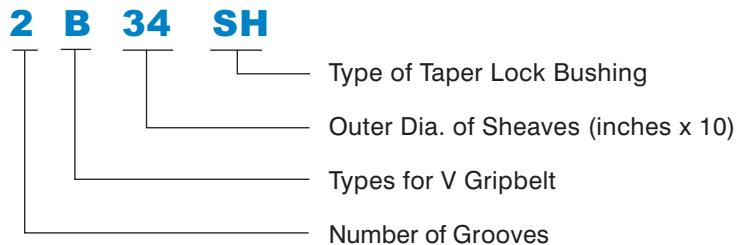

A/B-C-D

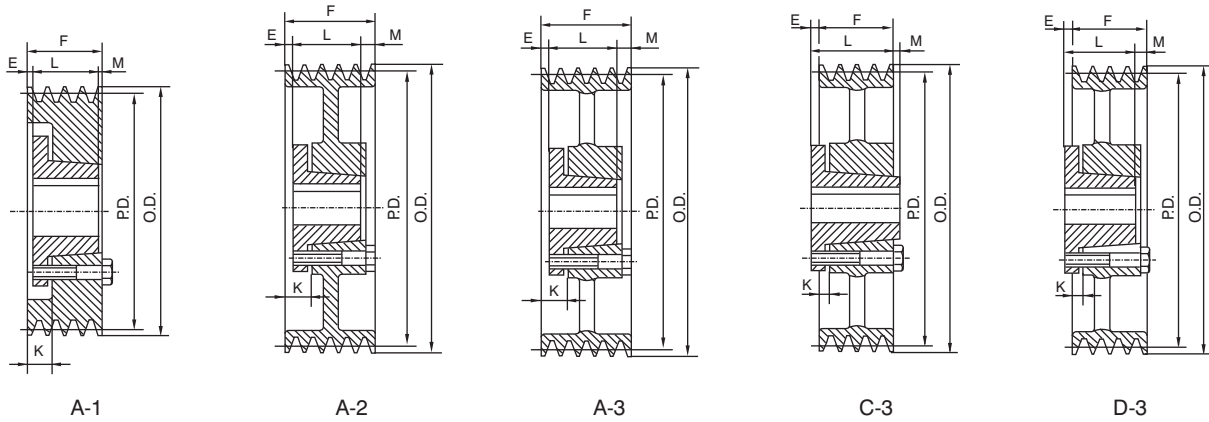

C-2

F=2 3/8" (60.33mm)

Part No.	O.D.	PD.	Bush Max Bore	Bush	Type	Db	E	K	L	M	Wgt. Less Bush
2 C 60 SK	6.40	6.00	25/8	SK	A1	—	3/16	7/8	1 15/16	1/8	8.0
2 C 70 SF	7.40	7.00	2 15/16	SF	A1	—	1/8	13/16	2 1/16	3/16	12.0
2 C 75 SF	7.90	7.50	2 15/16	SF	A1	—	1/8	13/16	2 1/16	3/16	15.0
2 C 80 SF	8.40	8.00	2 15/16	SF	A1	—	1/8	13/16	2 1/16	3/16	16.0
2 C 85 SF	8.90	8.50	2 15/16	SF	A2	5	1/8	13/16	2 1/16	3/16	19.0
2 C 90 SF	9.40	9.00	2 15/16	SF	A2	5	1/8	13/16	2 1/16	3/16	19.5
2 C 95 SF	9.90	9.50	2 15/16	SF	A2	5	1/8	13/16	2 1/16	3/16	21.0
2 C 100 SF	10.40	10.00	2 15/16	SF	A2	5	1/8	13/16	2 1/16	3/16	22.0
2 C 105 SF	10.90	10.50	2 15/16	SF	A2	5	1/8	13/16	2 1/16	3/16	25.0
2 C 110 SF	11.40	11.00	2 15/16	SF	A3	5	1/8	13/16	2 1/16	3/16	26.0
2 C 120 SF	12.40	12.00	2 15/16	SF	D3	5	1/8	9/16	2 1/16	7/16	29.0
2 C 130 SF	13.40	13.00	2 15/16	SF	D3	5	1/8	9/16	2 1/16	7/16	31.0
2 C 140 SF	14.40	14.00	2 15/16	SF	D3	5	1/8	9/16	2 1/16	7/16	35.0
2 C 150 SF	15.40	15.00	2 15/16	SF	D3	5	1/8	9/16	2 1/16	7/16	39.0
2 C 160 SF	16.40	16.00	2 15/16	SF	D3	5	1/8	9/16	2 1/16	7/16	43.0
2 C 180 SF	18.40	18.00	2 15/16	SF	D3	5	1/8	9/16	2 1/16	7/16	48.0
2 C 200 SF	20.40	20.00	2 15/16	SF	D3	5	1/8	9/16	2 1/16	7/16	55.0
2 C 240 SF	24.40	24.00	2 15/16	SF	D3	5	1/8	9/16	2 1/16	7/16	65.0
2 C 270 F	27.40	27.00	3 15/16	F	C3	7	11/16	5/16	3 5/8	9/16	107
2 C 300 F	30.40	30.00	3 15/16	F	C3	7	11/16	5/16	3 5/8	9/16	115

BORE RANGE FOR QTL BUSHING

Bush. Sym.	Min. Bore	Max. Bore with:		
		Full Keyway	Shallow Keyway	No Keyway
SK	1/2	2-1/8	2-1/2	2 5/8, 2 9/16
SF	1/2	2 1/4	2 7/8	2-15/16
E	7/8	2-7/8	3-1/2	—
F	1	3-1/4	3-15/16	4
J	1-1/2	3 13/16	4-1/2	—
M	2	4 11/16	5 1/2	—
N	2-7/16	5 1/16	5-7/8	—
P	2-15/16	5 13/16	7	—

STANDARD KEYWAY & KEY DIMENSION

Bores	Key Seat	Key
1/2-9/16	1/8x1/16	1/8x1/8
5/8-7/8	3/16x3/32	3/16x3/16
15/16-1 1/4	1/4x1/8	1/4x1/4
1 5/16-1 3/8	5/16x5/32	5/16x5/16
1 7/16-1 3/4	3/8x3/16	3/8x3/8
1 13/16-2 1/4	1/2x1/4	1/2x1/2
2 5/16-2 3/4	5/8x5/16	5/8x5/8
2 13/16-3 1/4	3/4x3/8	3/4x3/4
3 5/16-3 3/4	7/8x7/16	7/8x7/8
3 13/16-4 1/2	1x1/2	1x1
4 9/16-5 1/2	1 1/4x5/8	1 1/4x1 1/4
5 9/16-6 1/2	1 1/2x3/4	1 1/2x1 1/2
6 9/16-7 1/2	1 3/4x7/8	1 3/4x1 3/4

Dimensions: inch

FOR QTL TAPER BUSHING - SEE PAGE 10

A/B-C-D