

A/B-C-D • CAST IRON SHEAVES



LEESON offers a comprehensive line of A/B-C-D pulleys for "Quick Detachable" (QD) taper bushings.

Also referred to as classical V-Belt sheaves each item is made under ISO quality assurance systems.

Features:

GG25 high performance cast iron

Precision CNC machining

Precision balancing to 06.3

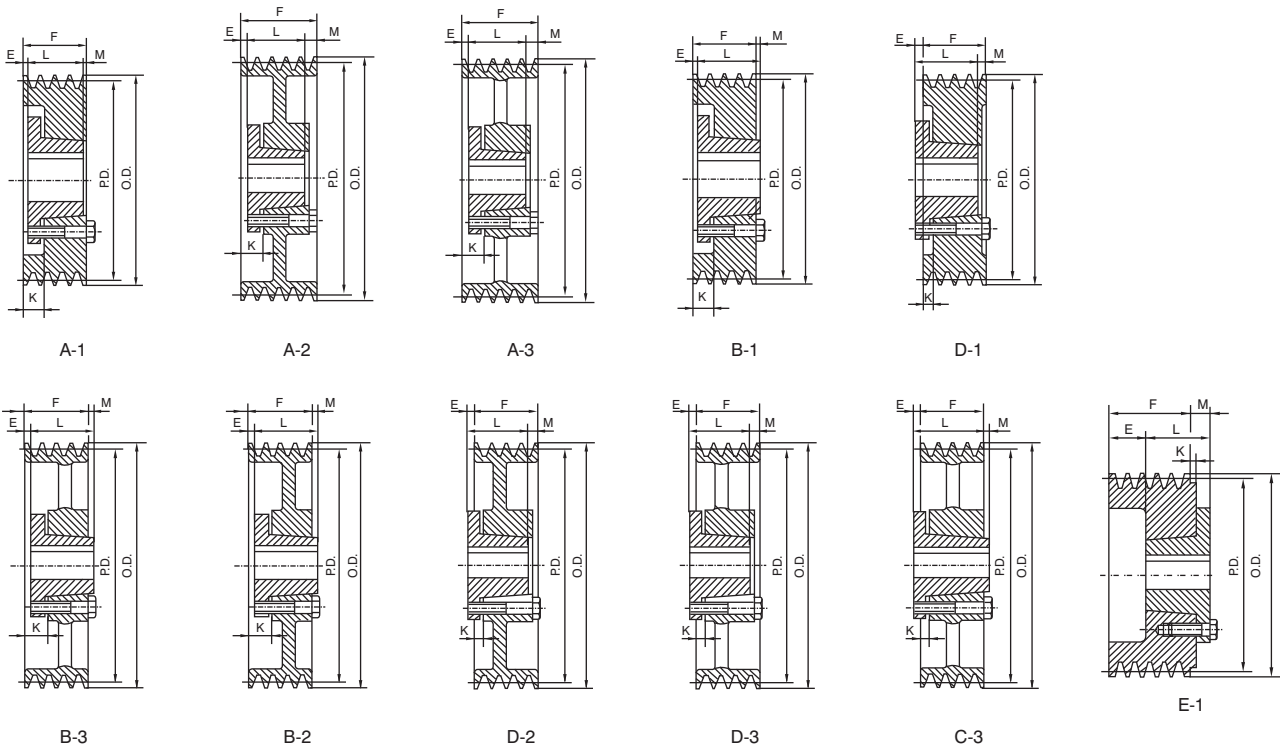

NOMENCLATURE FOR TAPER-LOCK SHEAVES FOR STANDARD NARROW V BELT

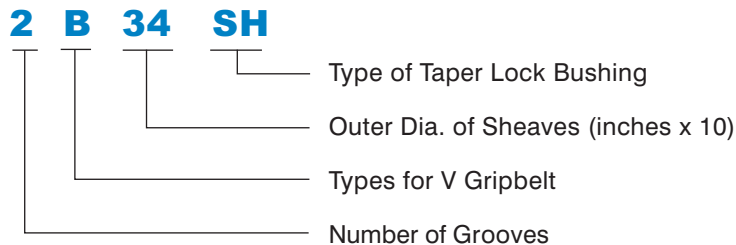

A/B-C-D

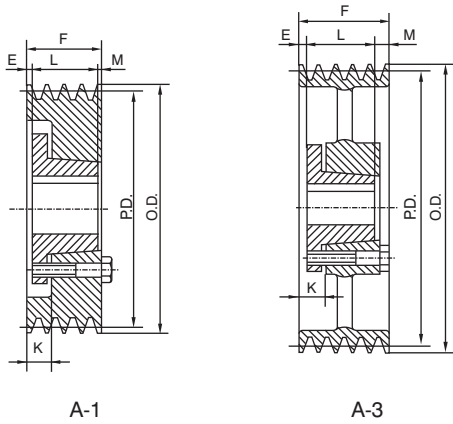

BORE RANGE FOR QTL BUSHING

Bush. Sym.	Min. Bore	Max. Bore with:		
		Full Keyway	Shallow Keyway	No Keyway
SF	1/2	2 1/4	2 7/8	2-15/16
E	7/8	2-7/8	3-1/2	—
F	1	3-1/4	3-15/16	4
J	1-1/2	3 13/16	4-1/2	—
M	2	4 11/16	5 1/2	—
N	2-7/16	5 1/16	5-7/8	—
P	2-15/16	5 13/16	7	—

C-8

F=8 3/8" (212.73mm)

Part No.	O.D.	P.D.	Bush Max Bore	Bush	Type	Db	E	K	L	M	Wgt. Less Bush
8 C 70 SF	7.40	7.00	2 15/16	SF	A1	—	25/16	3	2 1/16	4	35
8 C 75 SF	7.90	7.50	2 15/16	E	A1	—	25/16	3	2 1/16	4	37
8 C 80 E	8.40	8.00	3 1/2	E	A1	—	23/8	3 1/4	2 5/8	3 3/8	41
8 C 85 E	8.90	8.50	3 1/2	E	A1	—	23/8	3 1/4	2 5/8	3 3/8	50
8 C 90 F	9.40	9.00	3 15/16	F	A1	—	25/16	3 5/16	3 5/8	2 7/16	56
8 C 95 F	9.90	9.50	3 15/16	F	A1	—	25/16	3 5/16	3 5/8	2 7/16	60
8 C 100 F	10.40	10.00	3 15/16	F	A1	—	25/16	3 5/16	3 5/8	2 7/16	64
8 C 105 F	10.90	10.50	3 15/16	F	A1	—	25/16	3 5/16	3 5/8	2 7/16	74
8 C 110 F	11.40	11.00	3 15/16	F	A1	—	25/16	3 5/16	3 5/8	2 7/16	87
8 C 120 F	12.40	12.00	3 15/16	F	A1	—	25/16	3 5/16	3 5/8	2 7/16	94
8 C 130 F	13.40	13.00	3 15/16	F	A3	7	25/16	3 5/16	3 5/8	2 7/16	99
8 C 140 F	14.40	14.00	3 15/16	F	A3	7	25/16	3 5/16	3 5/8	2 7/16	110
8 C 150 F	15.40	15.00	3 15/16	F	A3	7	25/16	3 5/16	3 5/8	2 7/16	122
8 C 160 F	16.40	16.00	3 15/16	F	A3	7	25/16	3 5/16	3 5/8	2 7/16	136
8 C 180 F	18.40	18.00	3 15/16	F	A3	7	25/16	3 5/16	3 5/8	2 7/16	146
8 C 200 J	20.40	20.00	4 1/2	J	A3	7 3/4	3/8	1 9/16	4 1/2	3 1/2	195
8 C 240 J	24.40	24.00	4 1/2	J	A3	7 3/4	3/8	1 9/16	4 1/2	3 1/2	216
8 C 270 J	27.40	27.00	4 1/2	J	A3	7 3/4	3/8	1 9/16	4 1/2	3 1/2	268
8 C 300 J	30.40	30.00	4 1/2	J	A3	7 3/4	3/8	1 9/16	4 1/2	3 1/2	338
8 C 360 M	36.40	36.00	5 1/2	M	A3	9 1/2	1/2	1 15/16	6 3/4	1 1/8	413
8 C 440 M	44.40	44.00	5 1/2	M	A3	9 1/2	1/2	1 15/16	6 3/4	1 1/8	474
8 C 500 M	50.40	50.00	5 1/2	M	A3	9 1/2	1/2	1 15/16	6 3/4	1 1/8	503

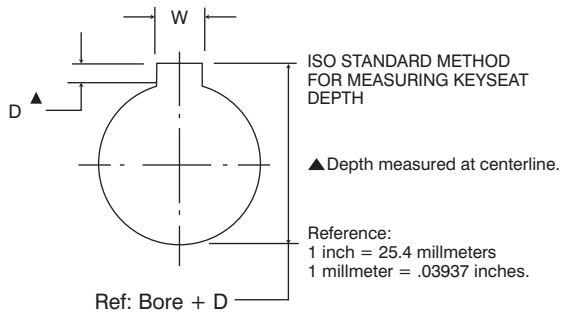

STANDARD KEYWAY & KEY DIMENSION

Bores	Key Seat	Key
1/2-9/16	1/8x1/16	1/8x1/8
5/8-7/8	3/16x3/32	3/16x3/16
15/16-1 1/4	1/4x1/8	1/4x1/4
1 5/16-1 3/8	5/16x5/32	5/16x5/16
1 7/16-1 3/4	3/8x3/16	3/8x3/8
1 13/16-2 1/4	1/2x1/4	1/2x1/2
2 5/16-2 3/4	5/8x5/16	5/8x5/8
2 13/16-3 1/4	3/4x3/8	3/4x3/4
3 5/16-3 3/4	7/8x7/16	7/8x7/8
3 13/16-4 1/2	1 x 1/2	1 x 1
4 9/16-5 1/2	1 1/4 x 5/8	1 1/4 x 1 1/4

A/B-C-D