

**3V-5V-8V • CAST IRON SHEAVES**

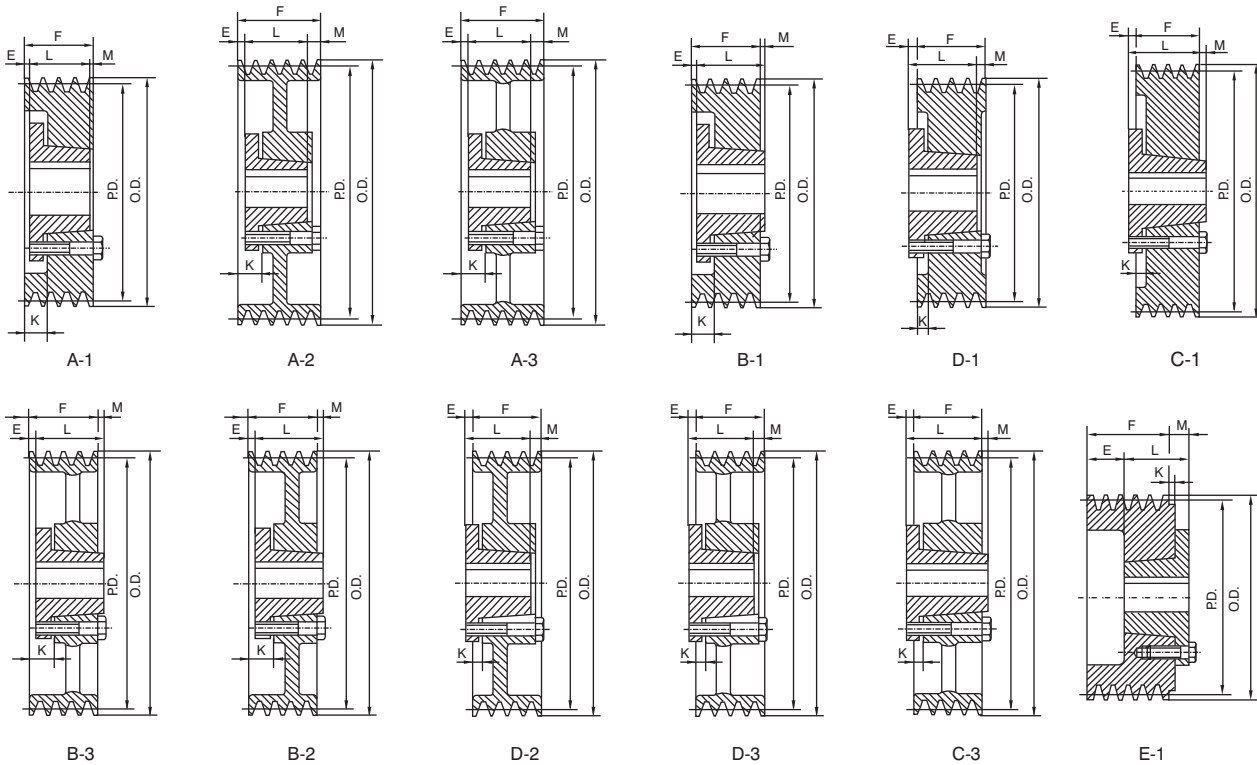

LEESON's series of taper bore V-pulleys are made of high-grade GG25 cast iron. They are matched with QTL "Quick Detachable" (QD) bushings for easy on-and-off use. These Narrow V-Belt sheaves offer higher horsepower than classical models and are suited to most power transmission installations.



**NOMENCLATURE FOR TAPER-LOCK SHEAVES  
FOR STANDARD NARROW V BELT**

**2 - 3V 220 - JA**

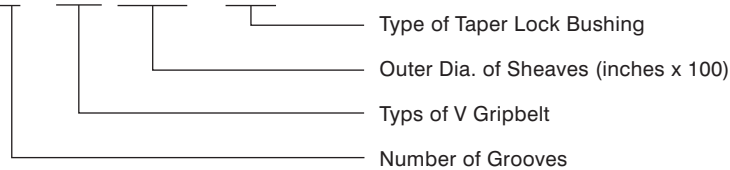

**FOR QTL TAPER BUSHING - SEE PAGE 10**

3V-5V-8V

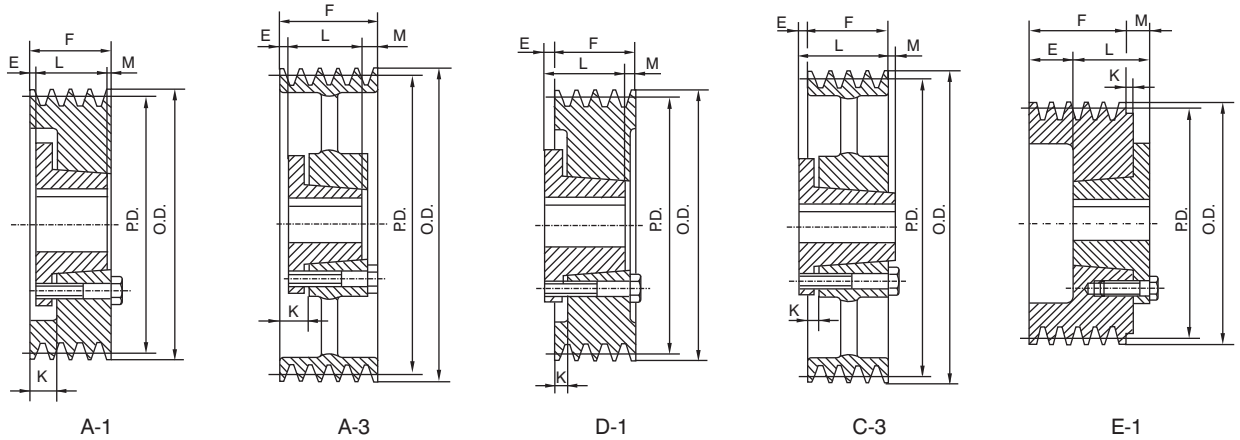

**3V-3**

**F=1 1/2"(38.10mm)**

Part No.	O.D.	P.D.	Bush Max Bore	Bush	Type	Db	E	K	L	M	Wgt. Less Bush
3-3V250-JA	2.50	2.45	1 1/4	JA	E1	2 3/8	1 3/8	7/16	1 1/16	15/16	1.6
3-3V265-JA	2.65	2.60	1 1/4	JA	D1	—	3/8	1/8	1 1/16	13/16	1.8
3-3V280-JA	2.80	2.75	1 1/4	JA	D1	—	3/8	1/8	1 1/16	13/16	2.0
3-3V300-JA	3.00	2.95	1 11/16	JA	E1	—	1 1/16	—	1 15/16	9/16	2.2
3-3V315-SH	3.15	3.10	1 11/16	SH	E1	3	1 1/16	5/16	1 5/16	7/8	2.5
3-3V335-SH	3.35	3.30	1 11/16	SH	D1	—	7/16	1/8	1 5/16	5/8	2.8
3-3V365-SH	3.65	3.60	1 11/16	SH	D1	—	7/16	1/8	1 5/16	5/8	3.0
3-3V412-SH	4.12	4.07	1 11/16	SH	A1	—	1/8	1 1/16	1 5/16	1/16	3.3
3-3V450-SDS	4.50	4.45	2	SDS	A1	—	1/16	1 1/16	1 3/8	1/16	3.5
3-3V475-SDS	4.75	4.70	2	SDS	A1	—	1/16	1 1/16	1 3/8	1/16	3.7
3-3V500-SDS	5.00	4.95	2	SDS	A1	—	1/16	1 1/16	1 3/8	1/16	4.0
3-3V530-SDS	5.30	5.25	2	SDS	A1	—	1/16	1 1/16	1 3/8	1/16	4.3
3-3V560-SDS	5.60	5.55	2	SDS	A1	—	1/16	1 1/16	1 3/8	1/16	4.9
3-3V600-SDS	6.00	5.95	2	SDS	A1	—	1/16	1 1/16	1 3/8	1/16	5.9
3-3V650-SDS	6.50	6.45	2	SDS	A3	3 1/2	1/16	1 1/16	1 3/8	1/16	6.3
3-3V690-SDS	6.90	6.85	2	SDS	A3	3 1/2	1/16	1 1/16	1 3/8	1/16	6.8
3-3V800-SK	8.00	7.95	2 5/8	SK	C2	4 3/8	7/16	1/4	1 15/16	—	10.8
3-3V1060-SK	10.60	10.55	2 5/8	SK	C3	4 3/8	7/16	1/4	1 15/16	—	12.0
3-3V1400-SK	14.00	13.95	2 5/8	SK	C3	4 3/8	7/16	1/4	1 15/16	—	20.0
3-3V1900-SF	19.00	18.95	2 15/16	SF	C3	5	7/16	1/4	2 1/16	1/8	33.0
3-3V2500-SF	25.00	24.95	2 15/16	SF	C3	5	7/16	1/4	2 1/16	1/8	45.0
3-3V3350-SF	33.50	33.45	2 15/16	SF	C3	5	7/16	1/4	2 1/16	1/8	75.0

3V-5V-8V