

## Installation and Service Instructions for 87,000 & 87,100 Series Self-Adjust Brakes (rev. B)

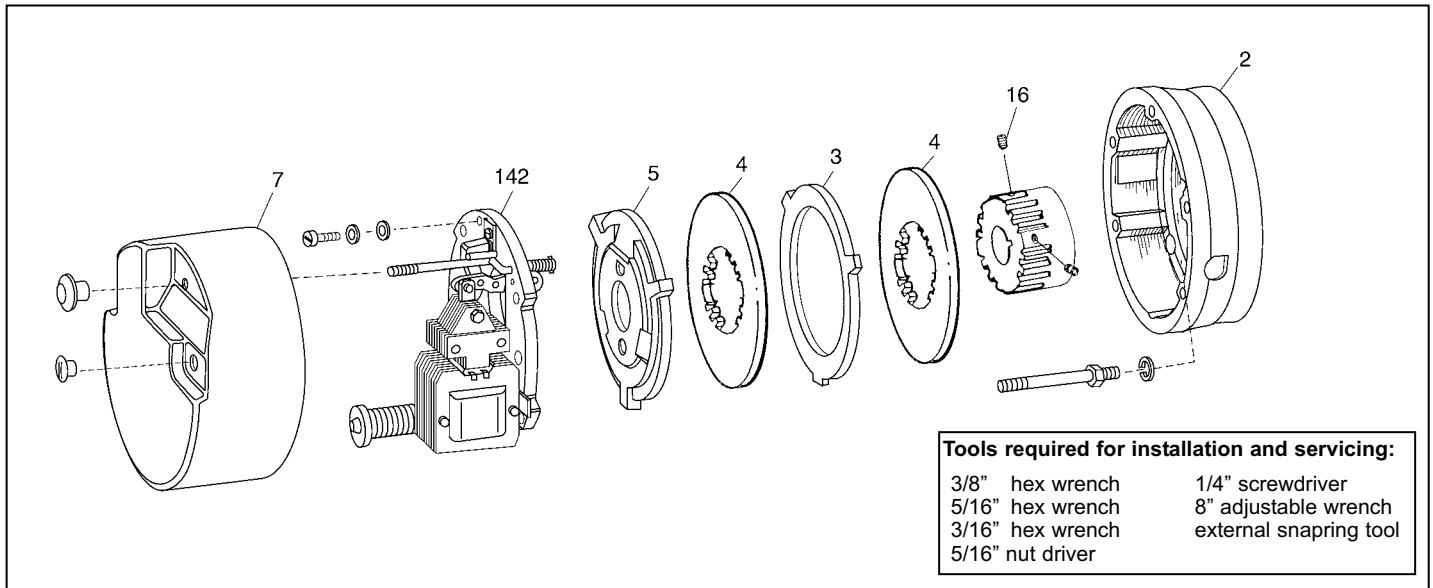

### Typical Nameplate

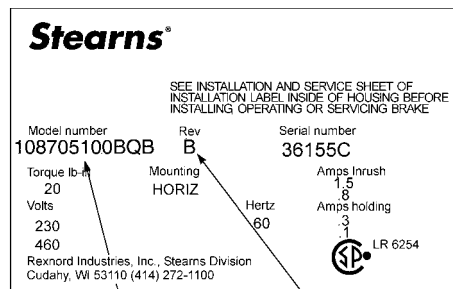

### Important

Please read these instructions carefully before installing, operating, or servicing your Stearns Brake. Failure to comply with these instructions could cause injury to personnel and/or damage to property if the brake is installed or operated incorrectly. For definition of limited warranty/liability, contact Rexnord Industries, Inc., Stearns Division, 5150 S. International Dr., Cudahy, WI 53110, (414) 272-1100.

### Caution

1. Installation and servicing must be made in compliance with all local safety codes including Occupational Safety and Health Act (OSHA). All wiring and electrical connections must comply with the National Electric Code (NEC) and local electric codes in effect.
2. Do not install the brake in atmospheres containing explosive gases or dusts.
3. To prevent an electrical hazard, disconnect power source before working

on the brake. If power disconnect point is out of sight, lock disconnect in the off position and tag to prevent accidental application of power.

4. Make certain power source conforms to the requirements specified on the brake nameplate.
5. Be careful when touching the exterior of an operating brake. Allow sufficient time for brake to cool before disassembly. Surfaces may be hot enough to be painful or cause injury.
6. Do not operate brake with housing removed. All moving parts should be guarded.
7. Installation and servicing should be performed only by qualified personnel familiar with the construction and operation of the brake.
8. For proper performance and operation, only genuine Stearns parts should be used for repairs and replacements.
9. After usage, the brake interior will contain burnt and degraded friction material dust. This dust must be removed before servicing or adjusting the brake.

DO NOT BLOW OFF DUST using an air hose. It is important to avoid dispersing dust into the air or inhaling it, as this may be dangerous to your health.

- a) Wear a filtered mask or a respirator while removing dust from the inside of a brake.
- b) Use a vacuum cleaner or a soft brush to remove dust from the brake. When brushing, avoid causing the dust to become airborne. Collect the dust in a container, such as a bag, which can be sealed off.

### General Description

These series of brakes are spring-set, electrically released. They contain one or more rotating friction discs (4) driven by a hub (16) mounted on the motor or other shaft.

### Operating Principle

These series contain one or more friction discs (4) assembled alternately between the endplate (2) friction surface, stationary disc(s) (3) and pressure plate (5). The stationary components are restrained from rotating by being keyed into the endplate. With the brake released, all disc pack components are free to slide axially and the friction disc(s) to rotate.

Brake release occurs when the solenoid coil is electrically energized, causing the solenoid plunger to travel a specified distance and through a lever system, overcoming the pressure spring force. This action releases the clamping force on the disc pack, thereby allowing the friction disc(s) and brake hub to rotate.

Brake sets and torque is produced when electric current to the solenoid coil is interrupted, thereby collapsing the solenoid magnetic field. The solenoid plunger returns to its original de-energized position allowing the lever arm to move forward by virtue of the compressed torque springs. This action compressed the disc pack components which applies a retarding torque to the brake hub and ultimately restores the brake to a spring-set static condition.

**Caution!** While the brake is equipped with a manual release to allow manual shaft rotation, the motor should not be run with the manual release engaged, to avoid overheating the friction disc(s).

# BRAKE MOUNTING

- 1** Remove manual release knob.  
Remove housing screws.  
Remove housing.

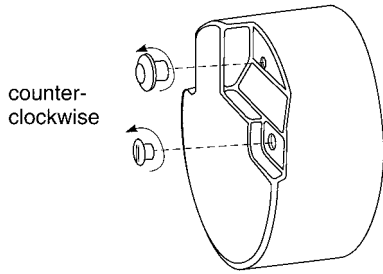

- 2** A. Push plunger down.  
B. Pull manual release to hold plunger.  
C. Remove support plate screws.

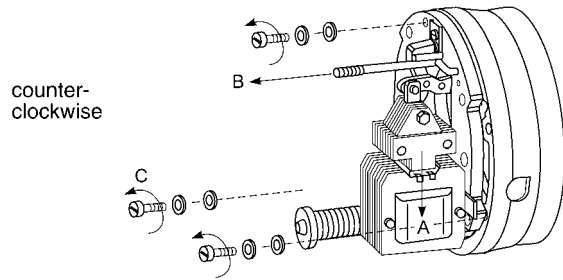

- 3** Lift off support plate.  
Remove disc pack.

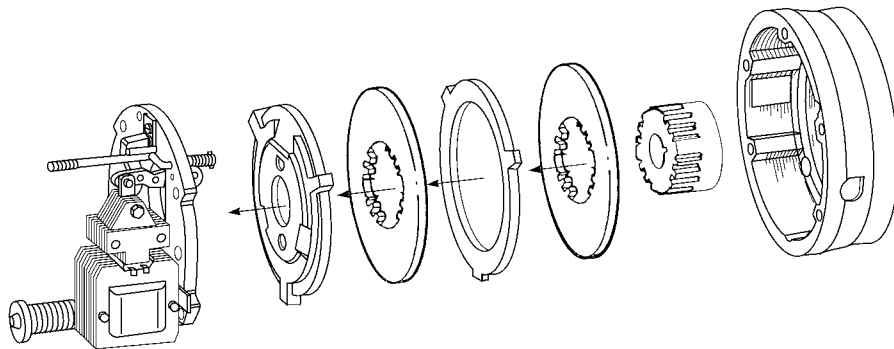

- 4** A. Position hub on shaft as shown.  
B. Tighten set screws to motor shaft.  
Torque to: 5/16" - 156 in-lb;  
3/8" - 288 in-lb;  
1/2" - 625 in-lb.

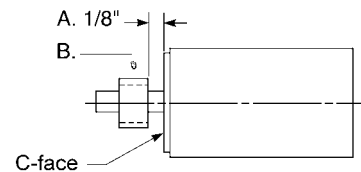

- 5** A. Position endplate on motor register.  
B. Insert four mounting bolts and tighten.  
C. Reassemble disc pack in reverse\* order of removal.

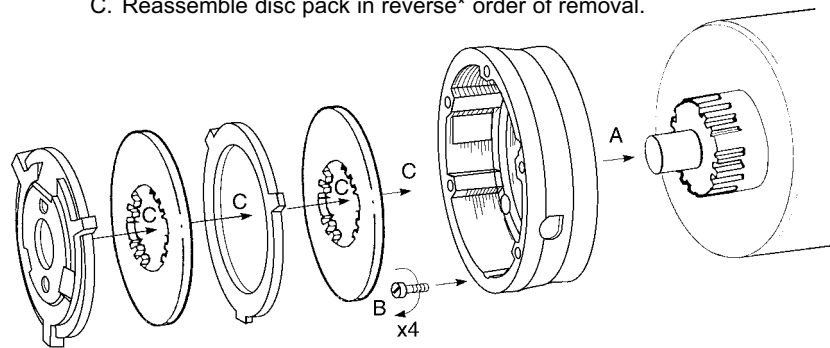

\*For vertical brakes, refer to Figure 2, page 3.

- 6** A. Route lead wires through conduit hole.  
B. Position support plate on endplate.  
C. Position conical washer under the screw head, with the flat washer\* against the support plate. Tighten screws to 50-55 in-lb.

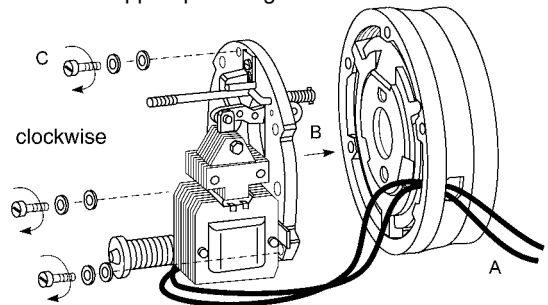

\*Cast iron support plates do not require a flat washer.

- 7** Coil wiring. Refer to nameplate for voltage rating\*.

**Caution:** Keep wiring away from pinch points.

### Coil Wiring

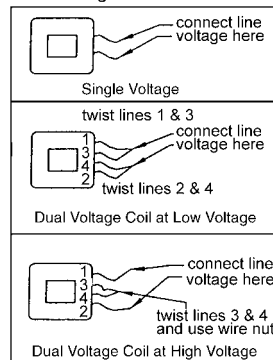

- 8** Replace housing.  
Tighten housing screws and release knob to 50-55 in-lb.

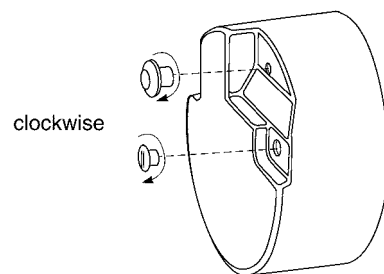

\* For DC voltages see sheet 8-078-950-00.

## Installation Notes:

**Note 1:** If motor is to be ceiling mounted after assembly, entire brake will have to be rotated 180° or “upside down” so it will be positioned with solenoid plunger (29) above frame when final assembly is mounted on ceiling. Similarly, for horizontal wall mounting, rotate 90°.

**Note 2:** The brake nameplate states mounting position; “horizontal, vertical above or vertical below.” The brake must be mounted in that position. Horizontal brakes rated 35 lb-ft and less do not require modification to be mounted vertical below.

**Note 3:** A dimple drilled into the motor shaft for the hub set screw (16S), 90° from the key is recommended for vertical mounting.

## General Maintenance

**Warning!** Any mechanism or load held in position by the brake should be secured to prevent possible injury to personnel or damage to equipment before any disassembly of the brake is attempted or before the manual release knob or lever is operated on the brake. Observe all cautions listed at the beginning of this manual.

**Note 1:** To obtain correct replacement parts for the Series 87,000 Marine Duty, obtain brake serial number and consult factory.

**Note 2:** Replace friction disc in single disc brakes when wear surface area is one-half the original disc thickness. In multiple disc brakes, replace all friction discs when throat of lever arm (17) is within 1/16” of touching teeth of pinion (32).

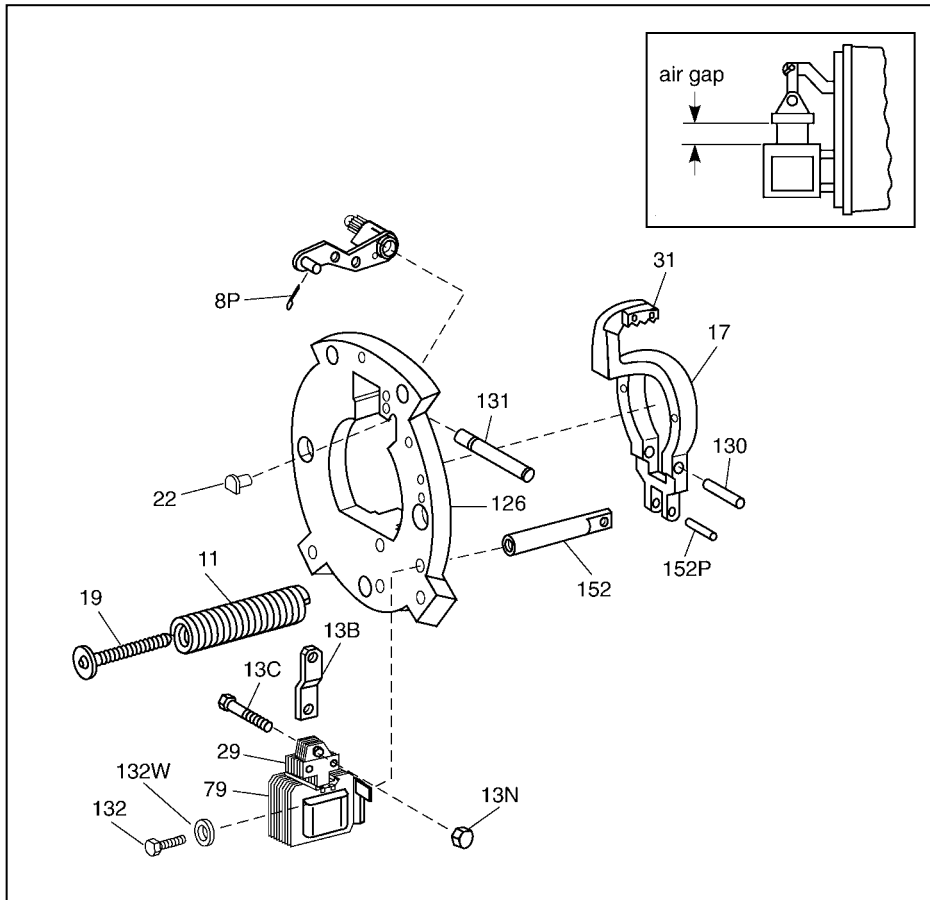

Figure 1

## Troubleshooting

### A. If brake does not stop properly or overheats, check the following:

1. Is manual release engaged, and is motor energized?
2. Friction discs may be excessively worn, charred or broken.
3. Hub may have become loose and shifted on shaft.
4. Are controls which govern start of braking cycles operating properly?
5. On vertically mounted brakes, are springs in place in disc pack?
6. Is solenoid air gap adjusted correctly? See *Air Gap Adjustment*, Page 4.
7. Solenoid lever stop (22) must be in place on support plate.
8. Solenoid may not be energizing and releasing the brake. Check voltage at the coil and compare to the coil and/or nameplate voltage rating.
9. Check that heads of mounting bolts do not extend above wear surface of endplate.
10. If stopping time is more than two seconds, the brake torque rating may be insufficient. If the brake stops high inertial loads and/or brake stops more than five times per minute, check thermal requirements of application versus thermal capacity rating of brake.

11. Use Loctite® 242 to secure link screw nut (13N) to link screw (13C) if vibration causes nut to loosen.

12. Check pressure spring length to insure correct compressed height. Original spring lengths are given in the following Table so that correct setting may be verified and corrected if necessary. With worn friction discs, add amount of wear to the approximate spring length shown.

Color	Torque (lb-ft)	Compressed Spring Length
Black	10	3-1/4"
White	15	3-1/4"
Orange	25 & 50	3-1/4"
Purple	35, 75 & 105	3-1/4"

13. If a heater is supplied and excess rusting has occurred in brake, check power source to heater to be sure it is operating and that heater is not burned out.

### B. If brake hums, solenoid pulls in slowly, or coil burns out, check the following:

1. Voltage supply at coil versus coil rating.
2. Is solenoid air gap excessive? See *Air Gap Adjustment*, Page 4.
3. Solenoid frame and plunger may be excessively worn.
4. Solenoid mounting screws may have become loose, causing frame to shift and plunger to seat improperly.

## Vertical Spring Assembly

**Note:** For vertical brakes refer to Figure 2 for proper stationary disc positioning. Discs must be inserted spring side first. Also refer to instruction sheet 8-078-937-06.

For brakes with brass stationary components, refer to instruction sheet 8-078-937-07.

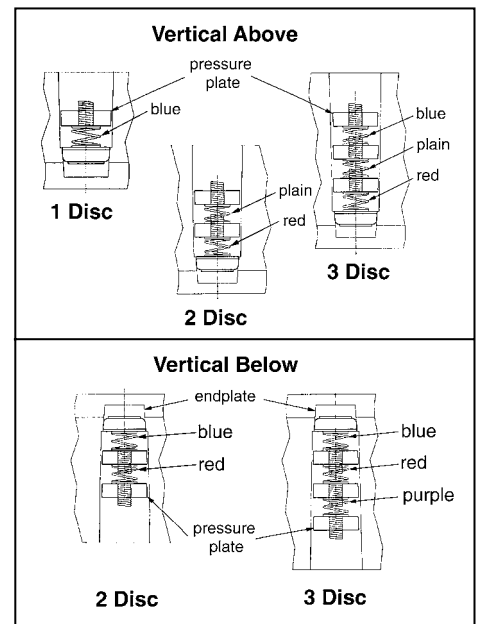
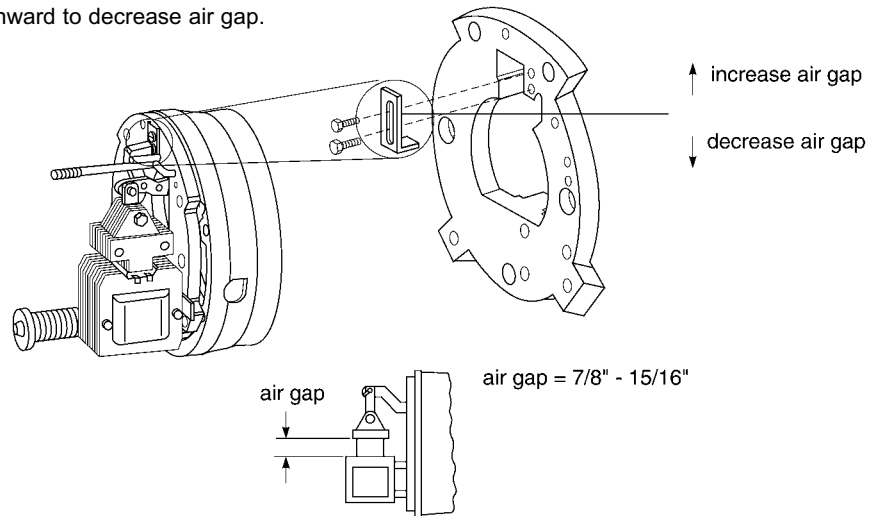

Figure 2

## AIR GAP AJUSTMENT

- 1** Loosen two locking screws.  
Slide bracket outward to increase or inward to decrease air gap.  
Tighten screws to 45-55 in-lb.



## COIL REPLACEMENT

- 1** Disconnect coil lead wires from power source and pull them out of the brake.

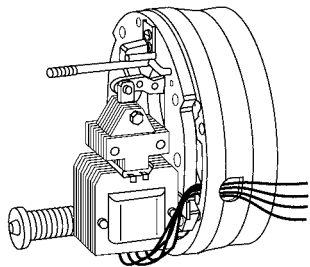

- 2** A. Remove solenoid mounting screws.  
B. Lift solenoid frame away from plunger.

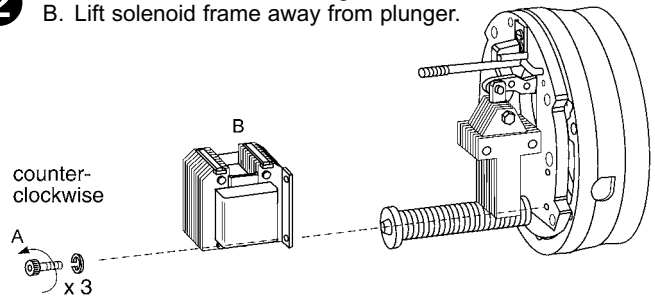

- 3** A. Remove guide screws, if used.  
B. Lift guides out of coil.  
C. Push coil out of frame.

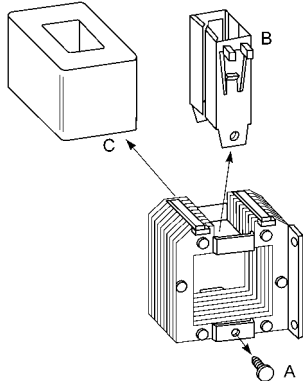

- 4** A. Insert new coil.  
B. Press plunger guides into place.  
C. (Guide screws are no longer required with plastic guides.)

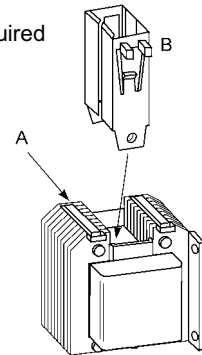

- 5** A. Slide coil assembly onto plunger.  
B. Insert mounting screws and tighten:  
50-55 in-lb (10-25 & 50 torque rated brake)  
100-110 in-lb (35, 75 & 105 torque rated brake)

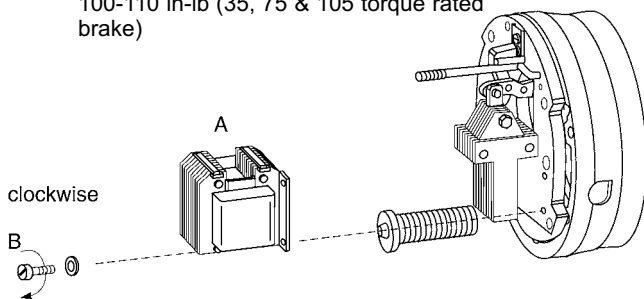

- 6** Reroute coil wires and reconnect to power supply.

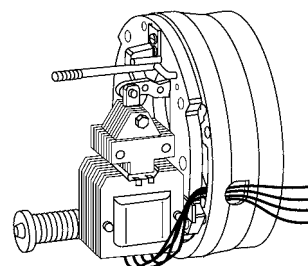

# FRICION DISC REPLACEMENT

- 1** Remove manual release knob.  
Remove housing screws.  
Remove housing.

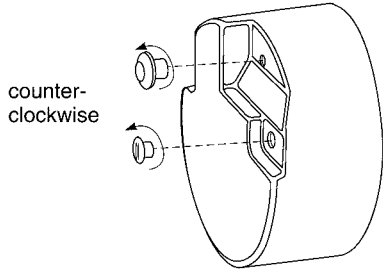

- 2** A. Push plunger down.  
B. Pull manual release to hold plunger  
C. Remove support plate screws.

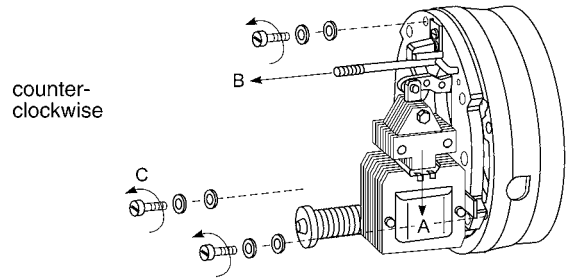

- 3** A. Remove support plate.  
B. Remove disc pack components.  
C. Discard old friction discs.

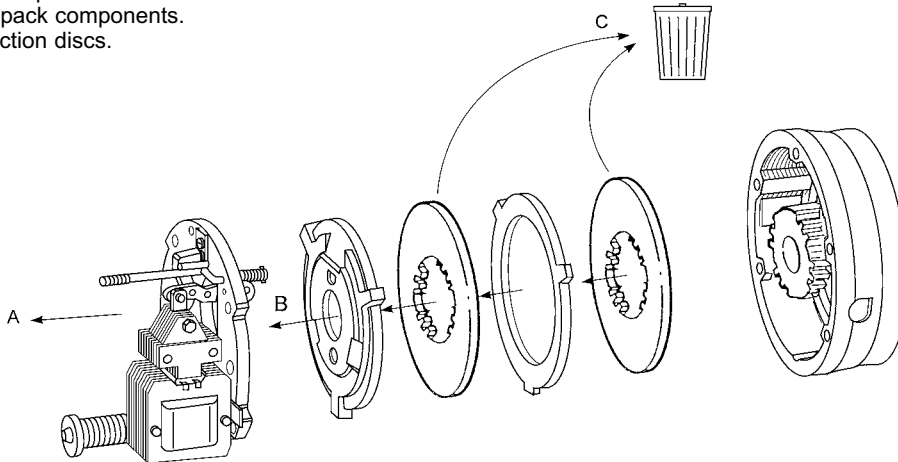

- 4** A. Install new friction discs and reassemble in reverse order of disassembly.\*  
B. Positioned conical washer under the screw head, with the flat washer against the support plate. **(Cast iron support plates do not require a flat washer)**. Tighten screws to 50-55 in-lb.

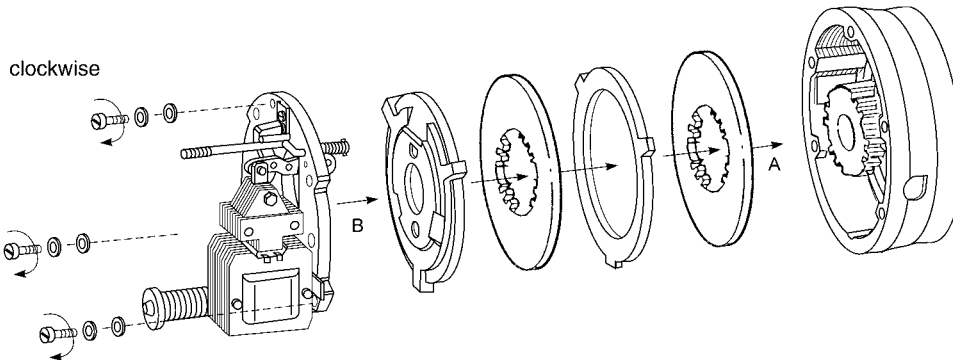

- 5** Replace housing.  
Tighten housing screws to 50-55 in-lb. Hand tighten release knob.

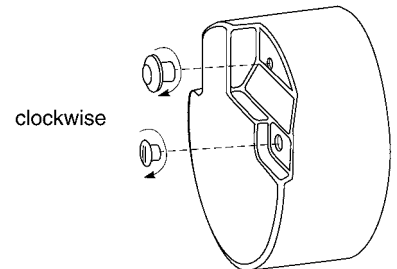

\* For vertical brake assembly refer to Figure 2, page 3.

**Information required when ordering replacement parts:**

- Give part number of parts or kits needed, brake model number, and brake serial number. The brake model and serial number may identify special brakes not covered by this parts list.
- Description items in ***CAPITALIZED BOLD ITALICS*** are recommended spare parts. One set per 5 brakes in service is recommended.
- For 87,100 Series see Table 2.

Circled items are contained in kit Item A, Table 4.

For installation and service instructions, see P/N 8-078-937-06.  
Detailed service instruction sheet is included with each kit.

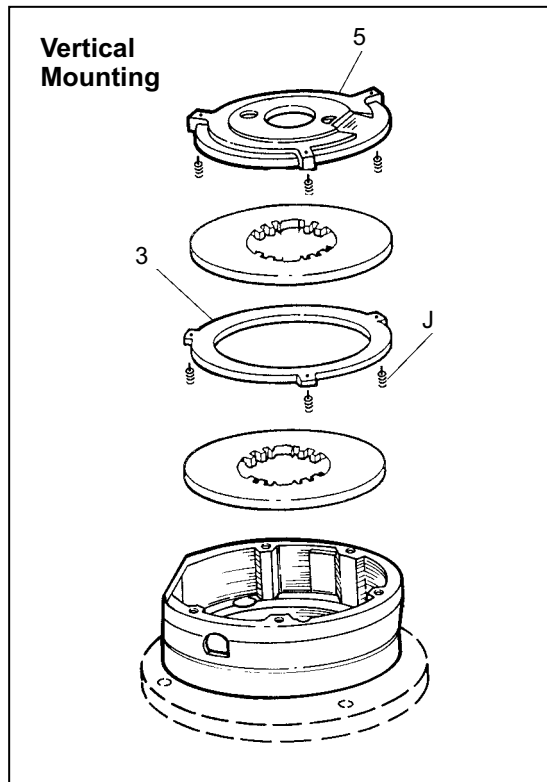
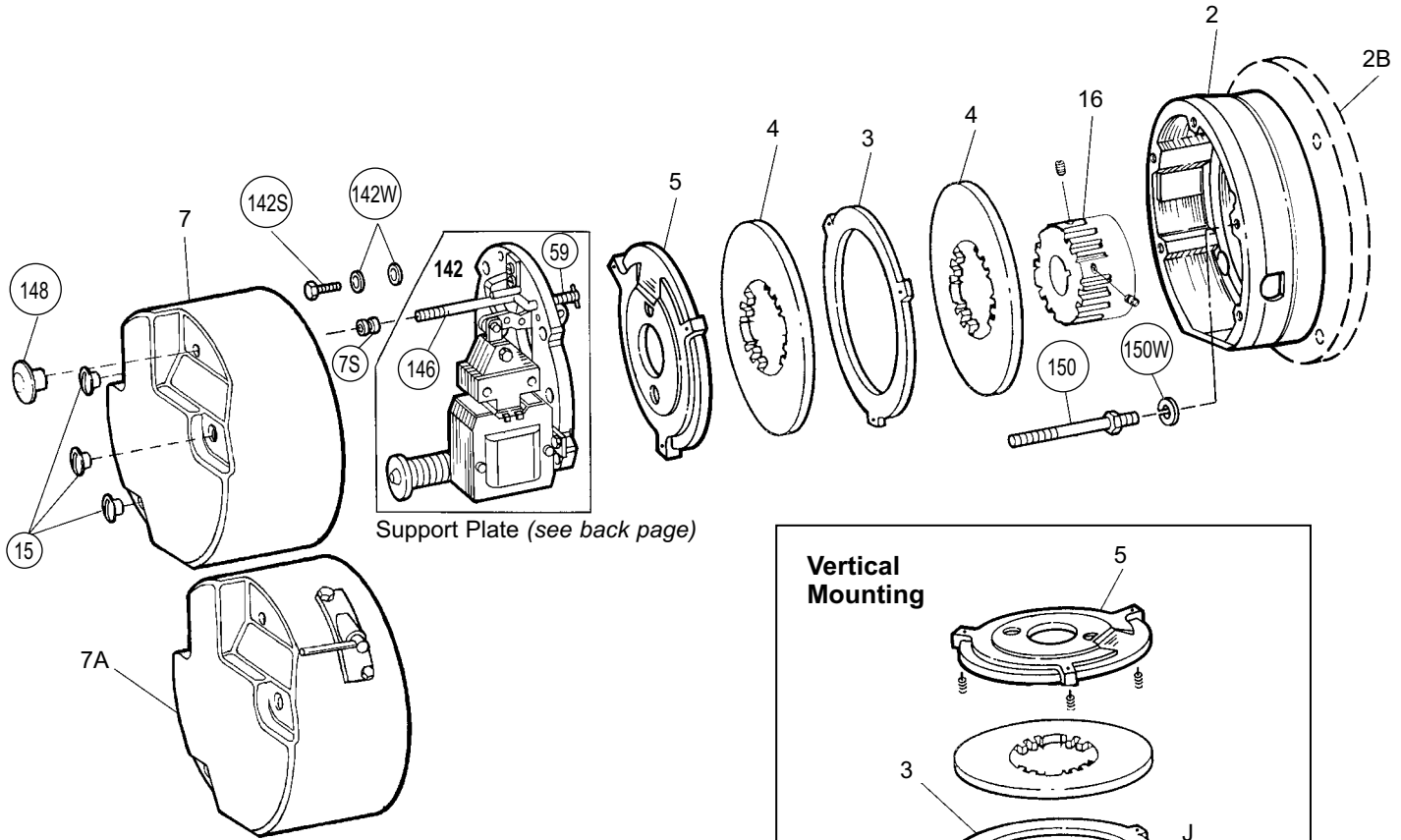

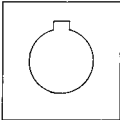
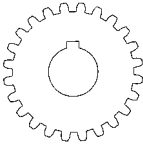
Old Configurations	
	
2.75" square	24 tooth 4.24 diameter

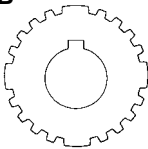
New Patented Design	
Rev. B	
	
20 tooth	3.12 diameter

**Stearns®**

SEE INSTALLATION AND SERVICE SHEET OR INSTALLATION LABEL INSIDE OF HOUSING BEFORE INSTALLING, OPERATING OR SERVICING BRAKE.

Model number <b>108705100EQB</b>	Rev. <b>B</b>	Serial number
Torque lb-ft	Mounting	Amps inrush
Volts	Hertz	Amps holding

Rexnord Corporation, Stearns Division  
Milwaukee, WI 53202 (414) 272-1100

LR 6254

**Note:**  
MODEL NUMBER will appear on brake nameplate.  
**REVISION CONTROL** (if applicable) and brake serial number

TABLE 1: Components of AC Brake

		Torque (lb-ft)	6			10			15			25			35			50			75			105				
		NEMA Enclosure	2	4	4x	2	4	4x	2	4	4x	2	4	4x	2	4	4x	2	4	4x	2	4	4x	2	4	4x		
		Brake Model Number *	1-087-001-00	1-087-002-00	1-087-004-00	1-087-011-00	1-087-012-00	1-087-014-00	1-087-021-00	1-087-022-00	1-087-024-00	1-087-031-00	1-087-032-00	1-087-034-00	1-087-041-00	1-087-042-00	1-087-044-00	1-087-051-00	1-087-052-00	1-087-054-00	1-087-061-00	1-087-062-00	1-087-064-00	1-087-081-00	1-087-082-00	1-087-084-00		
Item	Description	Part Number																										
A	<b>HARDWARE KIT</b>	5-66-1007-01	1	1	1	1	1	1	1	1	1	1	1	1	1	1	1	1	1	1	1	1	1	1	1	1	1	
2	Endplate, aluminum, 1 disc, NEMA 2 Endplate, aluminum, 2 disc, NEMA 2 Endplate, aluminum, 3 disc, NEMA 2 Endplate/seal, aluminum, 1 disc, NEMA 4 Endplate/seal, aluminum, 2 disc, NEMA 4 Endplate/seal, aluminum, 3 disc, NEMA 4	5-02-7004-01-30F 5-02-7005-01-30F 5-02-7006-01-30F 5-22-7066-00-30F 5-22-7067-00-30F 5-22-7068-00-30F	1			1			1			1			1			1			1			1			1	
2	Endplate/seal, cast iron, 1 disc, NEMA 4 Endplate/seal, cast iron, 2 disc, NEMA 4 Endplate/seal, cast iron, 3 disc, NEMA 4	5-22-7061-00-30F 5-22-7063-00-30F 5-22-7065-00-30F	1			1			1			1			1			1			1			1			1	
not shown	Gasket and seal kit, aluminum, NEMA 4 Gasket and seal kit, cast iron, NEMA 4 Drain plug, cast iron, NEMA 4	5-66-1271-01 5-66-1271-02 9-33-0325-00		1		1			1			1			1			1			1			1			1	
3	<b>STATIONARY DISC (HOR.-VERT.)</b>	5-66-8372-00																		1	1	1	1	1	1	2	2	2
4	<b>FRICITION DISC KIT, STANDARD</b> <b>FRICITION DISC KIT, SPECIAL DUTY</b>	5-66-8483-00 8-004-729-00	1	1	1		1	1	1	1	1	1	1	1	1	1	1	1	2	2	2	2	2	2	3	3	3	
5	<b>PRESSURE PLATE (HOR.-VERT.)</b>	5-66-8571-00	1	1	1	1	1	1	1	1	1	1	1	1	1	1	1	1	1	1	1	1	1	1	1	1	1	
7	Housing (front), aluminum, NEMA 2 Housing (front), aluminum, NEMA 4 Housing (front), cast iron, NEMA 2 and 4	5-07-7059-00 5-07-7057-00 5-07-7060-00	1			1			1			1			1			1			1			1			1	
7A	Housing (side), aluminum, NEMA 2 Housing (side), cast iron, NEMA 2 and 4	5-07-7052-00 5-07-7036-09	1	1		1	1		1	1		1	1		1	1		1	1		1	1		1	1		1	
16	Hub and set screw, 1 disc Hub and set screw, 2 disc Hub and set screw, 3 disc	5-16-7201-00* 5-16-7202-00* 5-16-7203-00*	1	1	1	1	1	1	1	1	1	1	1	1	1	1	1	1	1	1	1	1	1	1	1	1	1	
142	Support plate assembly Support plate assembly Support plate assembly Support plate assembly Support plate assembly	5-42-7089-00** 5-42-7091-00** 5-42-7093-00** 5-42-7095-00** 5-42-7097-00**	1	1	1		1	1	1		1	1	1		1	1	1		1	1	1		1	1	1	1	1	
J	<b>VERTICAL SPRING KIT (STANDARD)</b> <b>VERTICAL SPRING KIT (BRASS)</b>	5-66-3176-00 5-66-3177-00	1	1	1	1	1	1	1	1	1	1	1	1	1	1	1	1	1	1	1	1	1	1	1	1	1	
not shown	Brass stationary disc (horizontal-vertical) Brass pressure plate (horizontal-vertical)	8-003-704-04 8-005-703-12	1	1	1	1	1	1	1	1	1	1	1	1	1	1	1	1	1	1	1	1	1	1	2	2	2	
<b>VERTICAL BELOW-CAST IRON-NEMA 4 ONLY</b>																												
2	Endplate & seal assy 1 disc (cast iron) 2 disc (cast iron) 3 disc (cast iron)	5-22-7072-00-30F 5-22-7073-00-30F 5-22-7074-00-30F		1			1						1														1	

\*Bore diameter or full model number must be given when ordering.  
\*\*Coil is separate, consult factory for support plate assembly part number with the side release option.

**Support Plate Assembly**

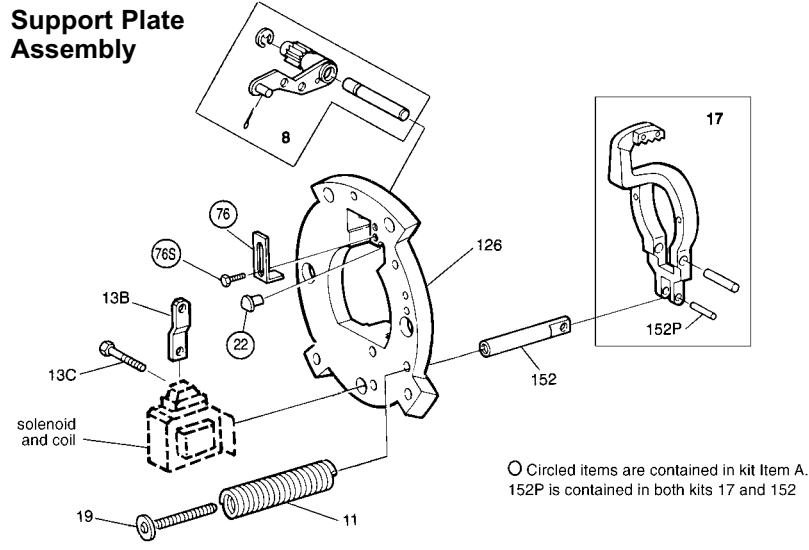

TABLE 2: For 284UC and 286UC or TC Frame NEMA "C" Flange

Item No.	Description	Part No.	Used on Models
2B	Endplate	8-002-909-01-30F	1-087-151-00, 1-087-155-00, 1-087-161-00 & 1-087-165-00
	Endplate	8-002-910-01-30F	1-087-181-00, & 1-087-185-00
	Endplate and*** oil seal assembly	5-22-7078-00-30F	1-087-152-00, 1-087-156-00, 1-087-162-00 & 1-087-166-00
	Endplate and*** oil seal assembly	5-22-7079-00-30F	1-087-182-00 & 1-087-186-00

\*\*\*For vertical below endplate consult the factory.

**TABLE 3: Components of Support Plate and Coil Assembly**

Item	Description	Part Number	Torque (lb-ft)			
			6 10	15	25 50	35 75 105
126	Support plate and bearing assembly Support plate and bearing assembly	5-26-7007-00 5-26-7008-00	1	1	1	1
8 17 19 & 152	<b>SOLENOID LEVER AND PINION KIT</b> Lever arm kit Pressure spring tube kit	5-66-7371-00 5-66-7271-00 5-66-7471-00	1	1	1	1
11	Pressure spring kit – black Pressure spring kit – white Pressure spring kit – orange Pressure spring kit – purple	5-66-3072-00 5-66-3074-00 5-66-3076-00 5-66-3078-00	1	1	1	1
<b>AC Brakes</b>						
U	<b>NO. 5 SOLENOID KIT</b> <b>NO. 6 SOLENOID KIT</b> <b>NO. 8 SOLENOID KIT</b>	5-66-5051-00 5-66-5061-00 5-66-5081-00	1	1	1	1
13B	Solenoid link Solenoid link	8-013-703-00 8-013-704-00	1	1	1	1
13C	Solenoid link cap screw Solenoid link cap screw Solenoid link cap screw	8-157-701-00 8-157-702-00 8-157-703-00	1	1	1	1
V	<b>No. 5 Coil kit 60 Hz</b> 115/230 Vac 230/460 Vac 115 Vac 230 Vac 460 Vac 575 Vac	5-66-6507-33 5-66-6509-33 5-66-6501-33 5-66-6502-33 5-66-6504-33 5-66-6505-33	1	1	1	1

\*Consult factory for price and availability on complete support plate assemblies including solenoid.

**Solenoid and Coil**

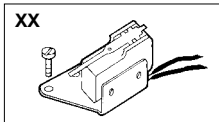
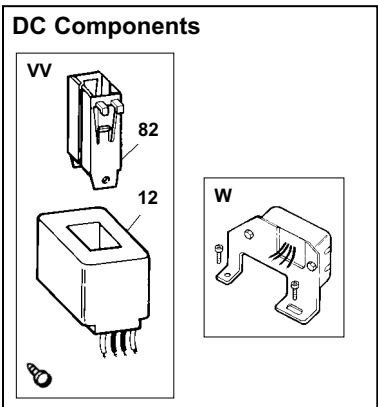
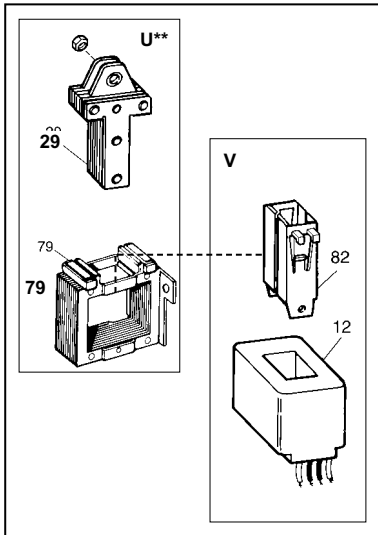

Item	Description	Part Number	Torque (lb-ft)				
			6 10	15	25 50	35 75 105	
V	<b>No. 6 Coil kit 60 Hz</b> 115/230 Vac 230/460 Vac 115 Vac 230 Vac 460 Vac 575 Vac	5-66-6607-33 5-66-6609-33 5-66-6601-33 5-66-6602-33 5-66-6604-33 5-66-6605-33	1	1	1	1	
	<b>No. 8 Coil kit 60 Hz</b> 115/230 Vac 230/460 Vac 115 Vac 230 Vac 460 Vac 575 Vac	5-66-6807-33 5-66-6809-33 5-66-6801-33 5-66-6802-33 5-66-6804-33 5-66-6805-33	1	1	1	1	
XX	Brake release interlock switch	5-57-5528-00	1	1	1	1	
<b>DC Brakes</b>							
W	Electronic DC Switch Kit	24/28 Vdc 115 Vdc 230 Vdc	5-57-5712-07 5-57-5716-07 5-57-5717-07	1	1	1	1
VV	<b>No. 5 Coil assembly</b>	115 Vdc 230 Vdc	5-96-6516-33 5-96-6517-33	1	1	1	
	<b>No. 6 Coil assembly</b>	115 Vdc 230 Vdc	5-96-6616-33 5-96-6617-33	1	1	1	
	<b>No. 8 Coil assembly</b>	115 Vdc 230 Vdc	5-96-6816-33 5-96-6817-33	1	1	1	

**TABLE 4: Contents of Kits and Assemblies (contents may vary)**

Item	Kit Description	Item	Kit Description
A	Hardware kit (5-66-1007-01) 2 – External lead wire plugs 1 – Wrap spring stop 2 – Wrap spring stop screws 1 – Solenoid lever stop 3 – Support plate screws 3 – Support plate conical spring washers 3 – Support plate flat washers 3 – Housing studs 3 – Housing stud lock washers 3 – Housing nuts 1 – Release rod 1 – Release rod spring 1 – Release spring retainer 1 – Housing grommet 1 – Release knob	17	Lever arm kit (5-66-7271-00) 1 – Lever arm assembly 1 – Lever arm pivot pin 1 – Spring tube pivot pin
	Gasket and seal kit (5-66-1271-0X) 1 – Endplate oil seal 1 – Housing seal 3 – Housing nut gaskets 1 – Housing to endplate gasket 3 – Endplate rubber plugs (-01 only) 1 – Manual release gasket (-01 only)	19 and 152	Pressure spring tube kit (5-66-7471-00) 1 – Pressure spring tube 1 – Pressure spring screw 1 – Spring tube pivot pin
3	Stationary disc kit (5-66-8372-00) 1 – Stationary disc (horizontal or vertical)	11	Pressure spring kit (5-66-307X-00) 1 – Pressure spring
4	Friction disc kit - splined (5-66-8483-00) 1 – Friction disc - splined	U	Solenoid kit (5-66-50X1-00) 1 – Plunger 1 – Frame 3 – Solenoid mounting screws 3 – Solenoid mtg. conical spring washers 1 – Solenoid link nut
5	Pressure plate kit (5-66-8571-00) 1 – Pressure plate (horizontal or vertical)	V	Coil kits (5-66-6XXX-33) AC coils 1 – Coil 2 – Plunger guides
J	Vertical spring kit (5-66-317X-00) 15 – Vertical above mounting springs	VV	Coil assembly (5-96-6XXX-33) DC coils 1 – Coil 2 – Plunger guides 4 – Wire fasteners
8	Solenoid lever and pinion kit (5-66-737X-00) 1 – Solenoid lever & pinion assembly 1 – Cotter pin 1 – Solenoid lever pivot pin 1 – Pivot pin retaining ring	W	DC switch kit (5-57-57XX-07) 1 – switch 1 – Mounting bracket 2 – Support plate mounting screws 2 – Switch mounting screws 2 – Nuts 3 – Crimp connectors
		XX	AC switch assembly (5-57-5528-00) 1 – Microswitch 1 – Mounting bracket 2 – Lead wire assemblies 2 – Mounting bracket screws 2 – Nuts 2 – Support plate screws 1 – Actuator arm 1 – Actuator arm mounting bolt 1 – Actuator arm nut



Rexnord Industries, Inc.  
Stearns Division  
5150 S. International Drive  
Cudahy, Wisconsin 53110  
(414) 272-1100 Fax: (414) 277-4364 www.rexnord.com