

## Parts List for 87,000 and 87,100 Series Brakes

### REV. A AND PRE-REVISION CONTROL (formerly Sheet 363.1)

#### Information required when ordering replacement parts:

- Give part number of parts or kits needed, brake model number, and brake serial number. The brake model and serial number may identify special brakes not covered by this parts list.
- Description items in **CAPITALIZED BOLD ITALICS** are recommended spare parts. One set per 5 brakes in service is recommended.
- Enclosures are designated as follows: **O** = Standard **E** = Dust-tight, waterproof (DTWP)
  - For 87,100 Series see Table 3.
- ◯Circled items are contained in kit Item A, Table 4.

For installation and service instructions, see P/N 8-078-927-00  
Detailed service instruction sheet is included with each kit.

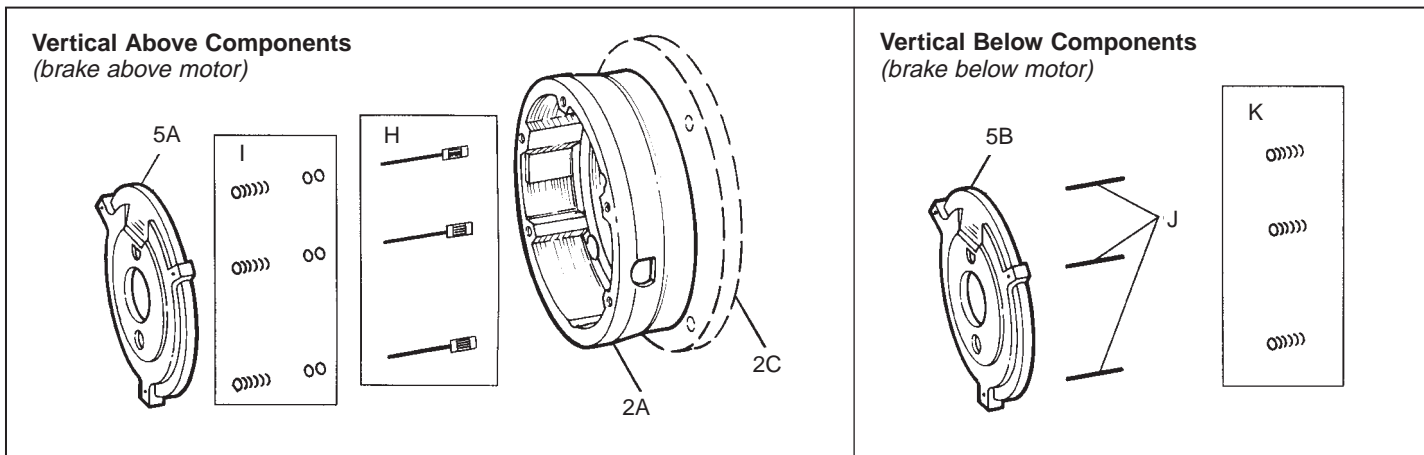
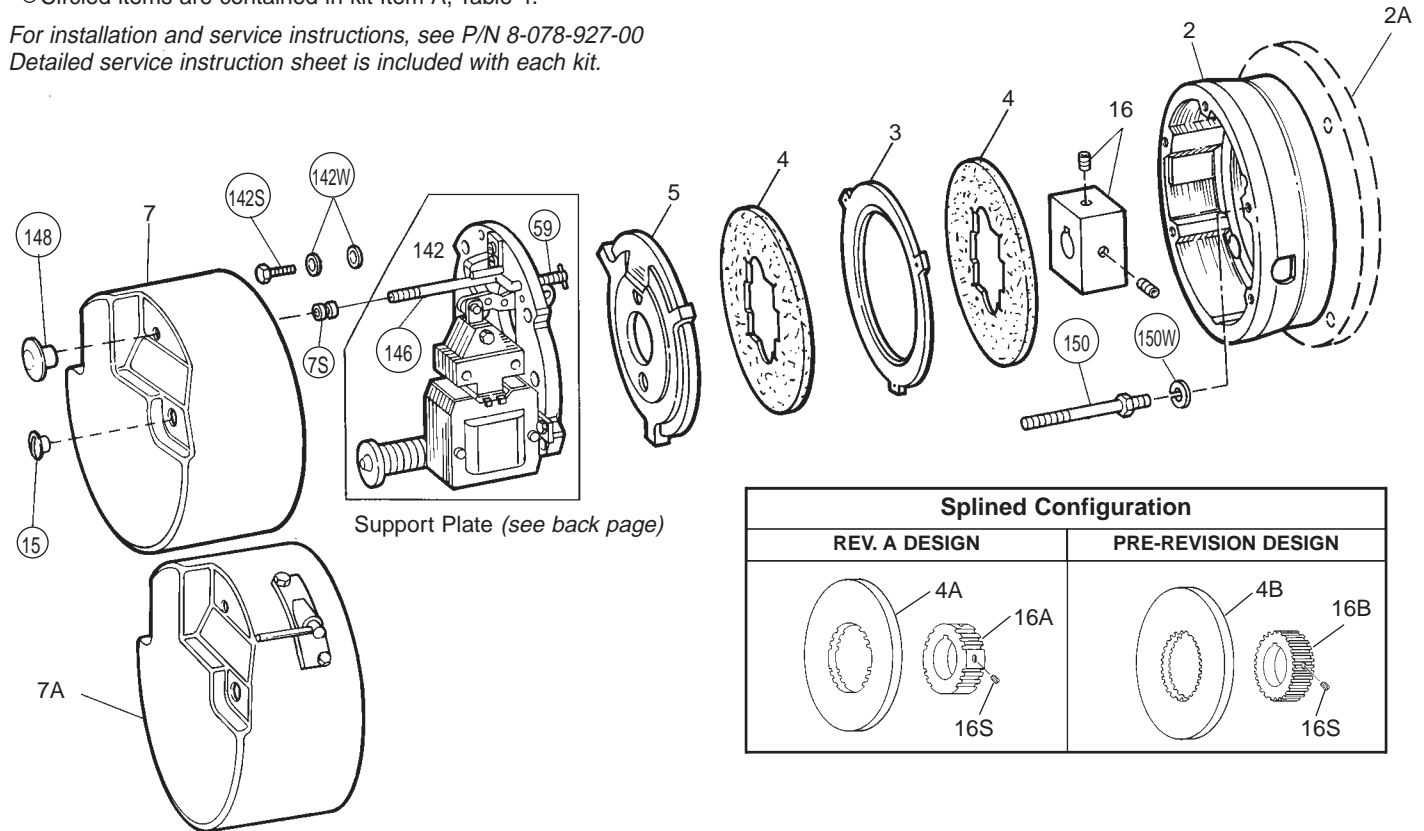

**Stearns®**

SEE INSTALLATION AND SERVICE SHEET OR INSTALLATION LABEL INSIDE OF HOUSING BEFORE INSTALLING, OPERATING OR SERVICING BRAKE.

Model number: 108705100EQB A  
 Rev. A  
 Serial number: [blank]  
 Torque lb-ft: [blank]  
 Mounting: [blank]  
 Volts: [blank]  
 Hertz: [blank]  
 Amps inrush: [blank]  
 Amps holding: [blank]

LR 6254

**Note:**  
**MODEL NUMBER**  
will appear on brake nameplate.

**REVISION CONTROL**  
(if applicable) and brake serial number.

**TABLE 1**  
Components of AC or DC Brake

Item	Description	Part Number ↓	Torque (lb-ft)		6		10		15		25		35		50		75		105																			
			Current		AC	DC	AC	DC	AC	DC	AC	DC	AC	DC	AC	DC	AC	DC	AC	DC	AC	DC																
			Enclosure	O	E	O	E	O	E	O	E	O	E	O	E	O	E	O	E	O	E	O	E															
		Brake Model Number →	1-087-001-00	1-087-002-00	1-087-005-00	1-087-006-00	1-087-011-00	1-087-012-00	1-087-015-00	1-087-016-00	1-087-021-00	1-087-022-00	1-087-025-00	1-087-026-00	1-087-031-00	1-087-032-00	1-087-035-00	1-087-036-00	1-087-041-00	1-087-042-00	1-087-045-00	1-087-046-00	1-087-051-00	1-087-052-00	1-087-055-00	1-087-056-00	1-087-061-00	1-087-062-00	1-087-065-00	1-087-066-00	1-087-081-00	1-087-082-00	1-087-085-00	1-087-086-00				
A	<b>HARDWARE KIT</b>	5-66-1007-00	1	1	1	1	1	1	1	1	1	1	1	1	1	1	1	1	1	1	1	1	1	1	1	1	1	1	1	1	1	1	1	1	1			
7	Housing and grommet assembly	5-07-7010-00	1																																			
7	Housing and seal assembly	5-07-7012-00	1	1	1	1	1	1	1	1	1	1	1	1	1	1	1	1	1	1	1	1	1	1	1	1	1	1	1	1	1	1	1	1	1			
7A	Housing assembly – side manual release	5-07-7051-00	1																																			
not shown	<b>GASKET AND SEAL KIT</b>	5-66-1271-00	1	1	1	1	1	1	1	1	1	1	1	1	1	1	1	1	1	1	1	1	1	1	1	1	1	1	1	1	1	1	1	1	1			
not shown	Pipe plug (drain)	9-33-0325-00	1	1	1	1	1	1	1	1	1	1	1	1	1	1	1	1	1	1	1	1	1	1	1	1	1	1	1	1	1	1	1	1	1	1		
5	<b>PRESSURE PLATE KIT</b>	5-66-8571-00	1	1	1	1	1	1	1	1	1	1	1	1	1	1	1	1	1	1	1	1	1	1	1	1	1	1	1	1	1	1	1	1	1	1		
4	<b>FRICION DISC KIT – STANDARD</b>	5-66-8472-00	1	1	1	1	1	1	1	1	1	1	1	1	1	1	1	1	1	1	1	1	1	1	1	1	1	1	1	1	1	1	1	1	1	1		
4	<b>FRICION DISC</b>	8-004-702-00	1	1	1	1																																
3	<b>STATIONARY DISC KIT (HORIZONTAL &amp; VERTICAL)</b>	5-66-8372-00																																				
16	Hub and set screw assembly (1-disc brake)	5-16-7101-00*	1	1																																		
	Hub and set screw assembly (2-disc brake)	5-16-7103-00*																																				
	Hub and set screw assembly (3-disc brake)	5-16-7105-00*																																				
	Hub and set screw assembly (1-disc brake)	5-16-7102-00*	1	1																																		
	Hub and set screw assembly (2-disc brake)	5-16-7104-00*																																				
	Hub and set screw assembly (3-disc brake)	5-16-7106-00*																																				
2	Endplate	5-02-7001-01	1	1																																		
	Endplate	5-02-7002-01																																				
	Endplate	5-02-7003-01																																				
	Endplate and oil seal assembly	5-22-7001-00	1	1																																		
	Endplate and oil seal assembly	5-22-7003-00																																				
	Endplate and oil seal assembly	5-22-7005-00																																				
142**	Support plate assembly (AC)	5-42-7089-00	1	1																																		
	Support plate assembly (AC)	5-42-7091-00																																				
	Support plate assembly (AC)	5-42-7093-00																																				
	Support plate assembly (AC)	5-42-7095-00																																				
	Support plate assembly (AC)	5-42-7097-00																																				
	Support plate assembly (DC)	5-42-7090-00																																				
	Support plate assembly (DC)	5-42-7092-00																																				
	Support plate assembly (DC)	5-42-7094-00																																				
	Support plate assembly (DC)	5-42-7096-00																																				
	Support plate assembly (DC)	5-42-7098-00																																				
<b>Vertical Above Modification (see Item 3, above for stationary disc kit)</b>																																						
5A	<b>PRESSURE PLATE</b>	8-005-702-04	1	1	1	1	1	1	1	1	1	1	1	1	1	1	1	1	1	1	1	1	1	1	1	1	1	1	1	1	1	1	1	1	1	1	1	
2A	Endplate with pins (aluminum)	5-20-7001-00	1	1																																		
	Endplate with pins (aluminum)	5-20-7002-00																																				
	Endplate with pins (aluminum)	5-20-7003-00																																				
	Endplate and seal assembly w/pins (cast iron)	5-22-7002-00	1	1																																		
	Endplate and seal assembly w/pins (cast iron)	5-22-7004-00																																				
	Endplate and seal assembly w/pins (cast iron)	5-22-7006-00																																				
H	Vertical above mounting pin kit (1-disc brake with cast iron endplate)	5-66-3371-00	1	1																																		
	Vertical above mounting pin kit (2-disc brake with cast iron endplate)	5-66-3372-00																																				
	Vertical above mounting pin kit (3-disc brake with cast iron endplate)	5-66-3373-00																																				
	Vertical above mounting pins (1-disc brake with aluminum endplate)	8-061-717-01	3	3																																		
	Vertical above mounting pins (2-disc brake with aluminum endplate)	8-061-718-01																																				
	Vertical above mounting pins (3-disc brake with aluminum endplate)	8-061-719-01																																				
I	<b>VERTICAL ABOVE SPRING AND SPACER KIT</b>	5-66-3171-00	1	1	1	1	1	1	1	1	1	1	1	1	1	1	1	1	1	1	1	1	1	1	1	1	1	1	1	1	1	1	1	1	1	1	1	
not shown	Housing and side release assembly	5-07-7036-00	1	1																																		
not shown	Side release adapter kit	5-55-7004-00	1	1																																		
<b>Vertical Below Modification (</b>																																						

**TABLE 2: Components of Support Plate and Coil Assembly**

Item	Description		Part Number	Torque (lb-ft)			
				6 10	15	25 50	35 75 105
126	Support plate and bearing assembly		5-26-7007-00	1	1	1	
	Support plate and bearing assembly		5-26-7008-00				1
8	<b>SOLENOID LEVER AND PINION KIT</b>		5-66-7371-00	1	1	1	1
17	Lever arm kit		5-66-7271-00	1	1	1	1
19 & 152	Pressure spring tube kit		5-66-7471-00	1	1	1	1
11	Pressure spring kit – black ( <i>formerly blue</i> )		5-66-3072-00	1			
	Pressure spring kit – white ( <i>formerly yellow</i> )		5-66-3074-00		1		
	Pressure spring kit – orange ( <i>formerly red</i> )		5-66-3076-00			1	
	Pressure spring kit – purple ( <i>formerly green</i> )		5-66-3078-00				1
<b>AC Brakes</b>							
U	<b>NO. 5 SOLENOID KIT</b>		5-66-5051-00	1			
	<b>NO. 6 SOLENOID KIT</b>		5-66-5061-00		1	1	
	<b>NO. 8 SOLENOID KIT</b>		5-66-5081-00				1
13B	Solenoid link		8-013-703-00	1	1	1	
	Solenoid link		8-013-704-00				1
13C	<b>SOLENOID LINK CAP SCREW</b>		8-157-701-00	1			
	<b>SOLENOID LINK CAP SCREW</b>		8-157-702-00		1	1	
	<b>SOLENOID LINK CAP SCREW</b>		8-157-703-00				1
V	<b>NO. 5 COIL KIT 60 HZ</b>	115/230 Vac	5-66-6507-33	1			
		230/460 Vac	5-66-6509-33	1			
		115 Vac	5-66-6501-33	1			
		230 Vac	5-66-6502-33	1			
		460 Vac	5-66-6504-33	1			
		575 Vac	5-66-6505-33	1			
	<b>NO. 6 COIL KIT 60 HZ</b>	115/230 Vac	5-66-6607-33		1	1	
		230/460 Vac	5-66-6609-33		1	1	
		115 Vac	5-66-6601-33		1	1	
		230 Vac	5-66-6602-33		1	1	
		460 Vac	5-66-6604-33		1	1	
		575 Vac	5-66-6605-33		1	1	
	<b>NO. 8 COIL KIT 60 HZ</b>	115/230 Vac	5-66-6807-33				1
		230/460 Vac	5-66-6809-33				1
		115 Vac	5-66-6801-33				1
		230 Vac	5-66-6802-33				1
		460 Vac	5-66-6804-33				1
		575 Vac	5-66-6805-33				1
X	Brake release interlock switch		5-57-5528-00	1	1	1	1
<b>DC Brakes</b>							
W	Electronic DC switch kit	24/28 Vdc	5-57-5712-07	1	1	1	1
		115 Vdc	5-57-5716-07	1	1	1	1
		230 Vdc	5-57-5717-07	1	1	1	1
UU	No. 5 DC solenoid assembly		5-12-5557-00	1			
	No. 6 DC solenoid assembly		5-12-5567-00		1	1	
	No. 8 DC solenoid assembly		5-12-5589-00				1
VV	No. 5 coil assembly	115 Vdc	5-96-6516-33	1			
		230 Vdc	5-96-6517-33	1			
	No. 6 coil assembly	115 Vdc	5-96-6616-33		1	1	
		230 Vdc	5-96-6617-33		1	1	
	No. 8 coil assembly	115 Vdc	5-96-6816-33				1
		230 Vdc	5-96-6817-33				1
XX	DC switch assembly		5-57-5501-00	1	1	1	1
Y	Arc suppression module		5-57-5711-00	1	1	1	1

\*Consult factory for price and availability on complete support plate assemblies including solenoid.

**TABLE 3: For 284UC and 286UC or TC Frame NEMA "C" Flange**

Suffix Letter	Item Number	Description	Part Number	Used on Models
	B	Endplate	8-002-761-01	1-087-151-00, 1-087-155-00, 1-087-161-00 & 1-087-165-00
		Endplate	8-002-762-01	1-087-181-00 & 1-087-185-00
		Endplate and oil seal assembly	5-22-7027-00	1-087-152-00, 1-087-156-00, 1-087-162-00 & 1-087-166-00
		Endplate and oil seal assembly	5-22-7029-00	1-087-182-00 & 1-087-186-00
A	C	<b>Vertical Mounting – above Motor</b>		
		Endplate with pins	5-20-7022-00	1-087-151-00, 1-087-155-00, 1-087-161-00 & 1-087-165-00
		Endplate with pins	5-20-7023-00	1-087-181-00 & 1-087-185-00
		Endplate and seal assembly with pins	5-22-7028-00	1-087-152-00, 1-087-156-00, 1-087-162-00 & 1-087-166-00
		Endplate and seal assembly with pins	5-22-7030-00	1-087-182-00 & 1-087-186-00

**Note:** Brakes with a no. 5 or no. 6 solenoid manufactured before June 17, 1971 (prior to serial no. B-695468), or with a no. 8 solenoid manufactured before September 13, 1971 (prior to serial no. B-787975) contained a cast iron support plate (126) and lever arm (17). On subsequent brakes, these components have been changed to die cast aluminum. If either of the cast iron components need to be replaced, both must be replaced. However, in such a case, replacement of the entire support plate assembly (PP) is recommended.

## Support Plate Assembly

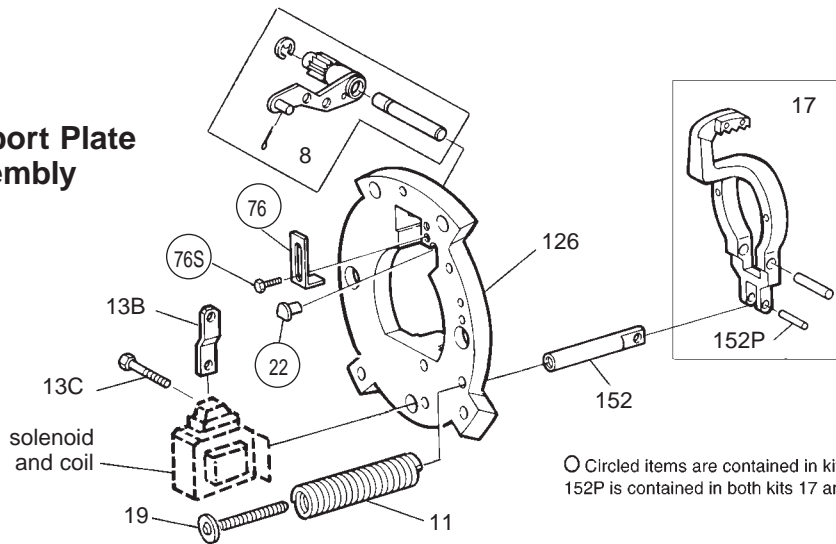

○ Circled items are contained in kit Item A.  
152P is contained in both kits 17 and 152

## Solenoid and Coil Assembly

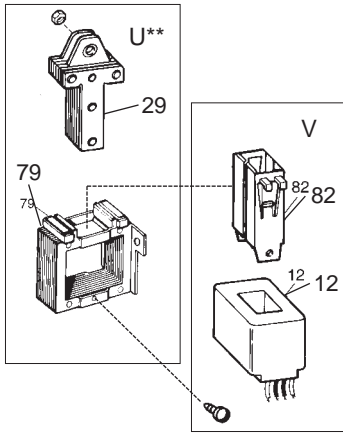

## DC Components

With Electronic Switch

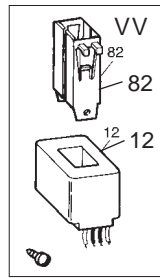

With Mechanical Switch

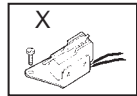
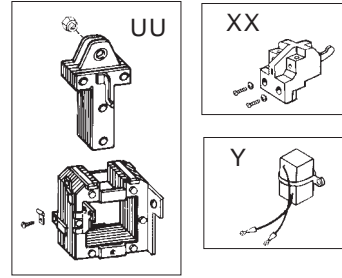

TABLE 4: Contents of Kits and Assemblies (contents may vary)

Item	Kit Description	Item	Kit Description	Item	Kit Description
A	Hardware kit (5-66-1007-00) 2 – External lead wire plugs 1 – Wrap spring stop 2 – Wrap spring stop screws 1 – Solenoid lever stop 3 – Support plate screws 3 – Support plate conical spring washers 3 – Support plate flat washers 2 – Housing studs 2 – Housing stud lock washers 2 – Housing nuts 1 – Release rod 1 – Release rod spring 1 – Release spring retainer 1 – Housing grommet 1 – Release knob	I	Vertical above spring and spacer kit (5-66-3171-00) 9 – Vertical above mounting springs 9 – Vertical above spring spacers	VV	Coil assembly (5-96-6XXX-33) DC coils 1 – Coil 2 – Plunger guides 2 – Plunger guide screws 4 – Wire fasteners
	Gasket and seal kit (5-66-1271-00) 1 – Endplate oil seal 1 – Housing seal 2 – Housing nut gaskets 1 – Housing to endplate gasket 3 – Lead wire bushings 1 – Pipe plug	K	Vertical below spring kit – green (5-66-3172-00) 3 – Vertical below springs - green Vertical below spring kit - red (5-66-3173-00) 3 – Vertical below springs - red	W	DC switch kit (5-57-57XX-07) 1 – Switch 1 – Mounting bracket 2 – Support plate mounting screws 2 – Switch mounting screws 2 – Nuts 3 – Crimp connectors
5	Pressure plate kit (5-66-8571-00) 1 – Pressure plate	8	Solenoid lever & pinion kit (5-66-7371-00) 1 – Solenoid lever and pinion assembly 1 – Cotter pin 1 – Solenoid lever pivot pin 1 – Pivot pin retaining ring	X	AC switch assembly (5-57-5528-00) 1 – Microswitch 1 – Mounting bracket 2 – Lead wire assemblies 2 – Mounting bracket screws 2 – Nuts 2 – Support plate screws 1 – Actuator arm 1 – Actuator arm mounting bolt 1 – Actuator arm nut
4	Friction disc kit - standard (5-66-8472-00) 1 – Friction disc - standard Friction disc kit - splined (5-66-8478-00) 1 – Friction disc -splined	17	Lever arm kit (5-66-7271-00) 1 – Lever arm assembly 1 – Lever arm pivot pin 1 – Spring tube pivot pin	XX	DC switch assembly (5-57-5501-00) 1 – DC switch 2 – Mounting screws 2 – Lock washers
3	Stationary disc kit (5-66-8372-00) 1 – Stationary disc (horizontal or vertical)	19 and 152	Pressure spring tube kit (5-66-7471-00) 1 – Pressure spring tube 1 – Pressure spring screw 1 – Spring tube pivot pin	Y	Arc suppression module (5-57-5711-00) 1 – Arc suppression module 1 – Cable strap
H	Vertical above mounting pin kit (5-66-337X-00) 3 – Vertical above mounting pins	11	Pressure spring kit (5-66-307X-00) 1 – Pressure spring		
		U and UU	Solenoid kit (5-66-50X1-00) (5-12-55XX-00) 1 – Plunger 1 – Frame 3 – Solenoid mounting screws 3 – Solenoid mtg. conical spring washers 1 – Solenoid link nut		
		V	Coil kits (5-66-6XXX-33) AC coils 1 – Coil 2 – Plunger guides 2 – Plunger guide screws		